

PARTS LIST

ITEM NO.	DESCRIPTION	DWG. NO
1	HEATER BLANKET	270-001
2	H050-OWB	800-004
3	O-RING	450-002
4	STROBE LIGHT BULB	270-008
5	QDC - M,F	430-001,002
6	DELAY TIMER	230-014
7	MOTOR	780-018
8	PUMP	770-019
9	TEMPERATURE GAUGE	610-003
10	VACUUM GAUGE	510-012
11	DRAIN COCK	430-004
12	PRESSURE GAUGE	610-010
13	PRESSURE SWITCH	620-001
14	PRESSURE GAUGE	610-009
15	LID CLAMP	540-005
16	CHECK VALVE(optional)	

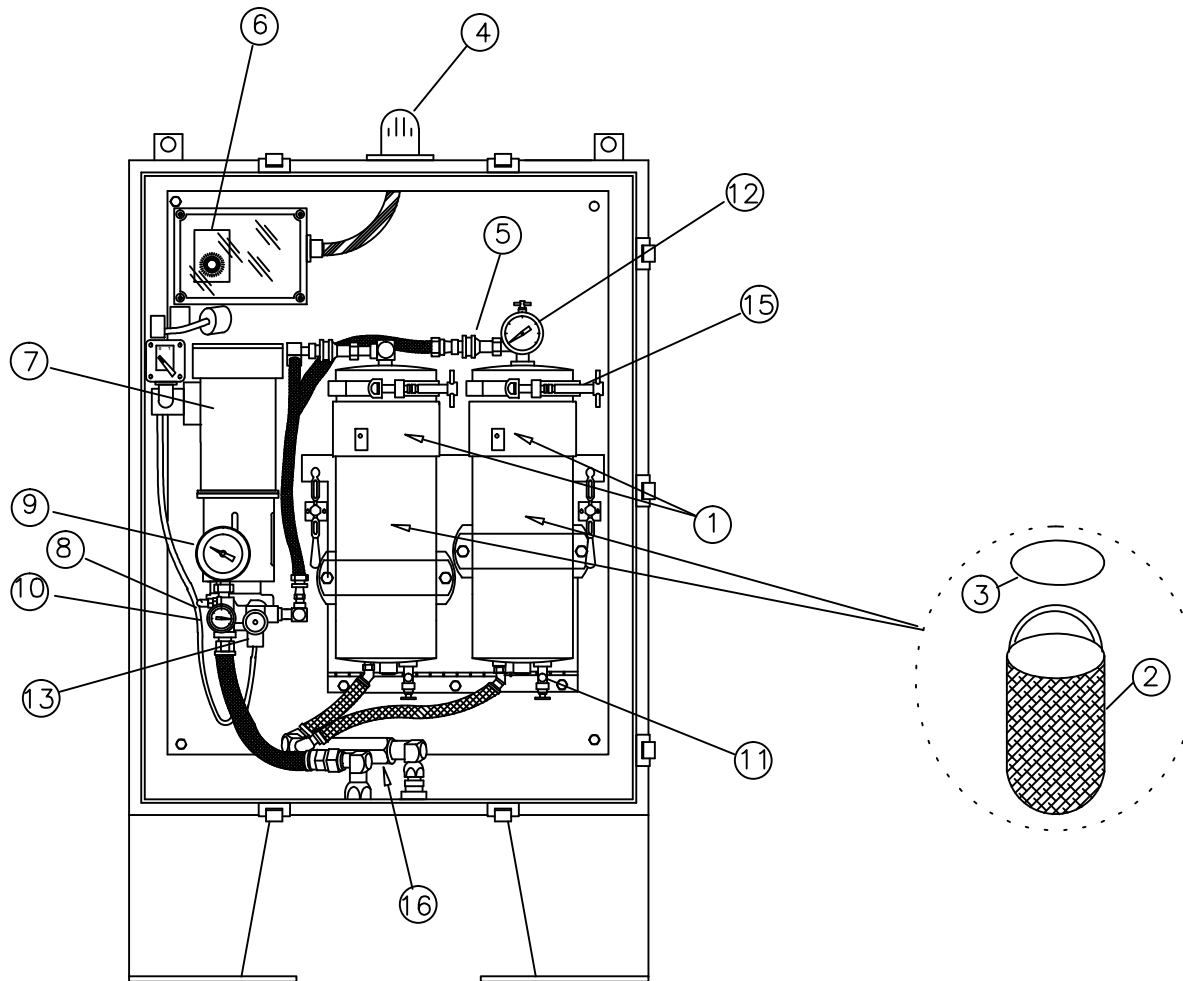

DWG. TITLE		HTI		820-009		
820-009 C PARTS DRAWING		FILTRATION				
PROJECT DESCRIPTION		11820 WESTERN AVE.		C	9/12/01	SP
WATER REMOVAL SYSTEM		STANTON		REV.	DATE:	DRWN BY
JOB NO.	DRAWING NO.	REVISION	CUST. CONTR. NO.	CA	90680	SP
-	820-009CPL	C	-	CUSTOMER	-	-
				CHKD BY	DESCRIPTION	