

ASSEMBLY MOUNTING ARRANGEMENT
WITH SS FITTINGS PACKAGE

KIT NUMBER 460-049
HEAVY DUTY WASH DOWN MOTOR/PUMP ASSEMBLY
1/2 HP 180-415V 50 Hz, 230-460V-60 Hz
.50 GPM OUTPUT W/ RELIEF VALVE
ANGELUS PART NUMBER F0161L814AAB0

KIT NUMBER 460-043
HEAVY DUTY WASH DOWN MOTOR/PUMP ASSEMBLY
1/2 HP - 575V- 60 Hz
.50 GPM OUTPUT W/ RELIEF VALVE
ANGELUS PART NUMBER F016L814AA2

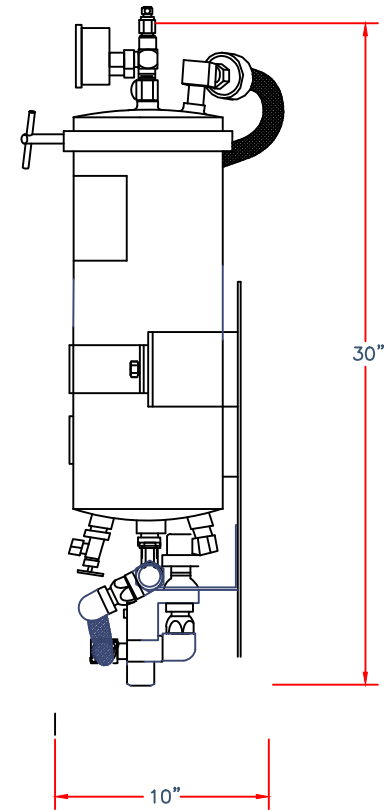
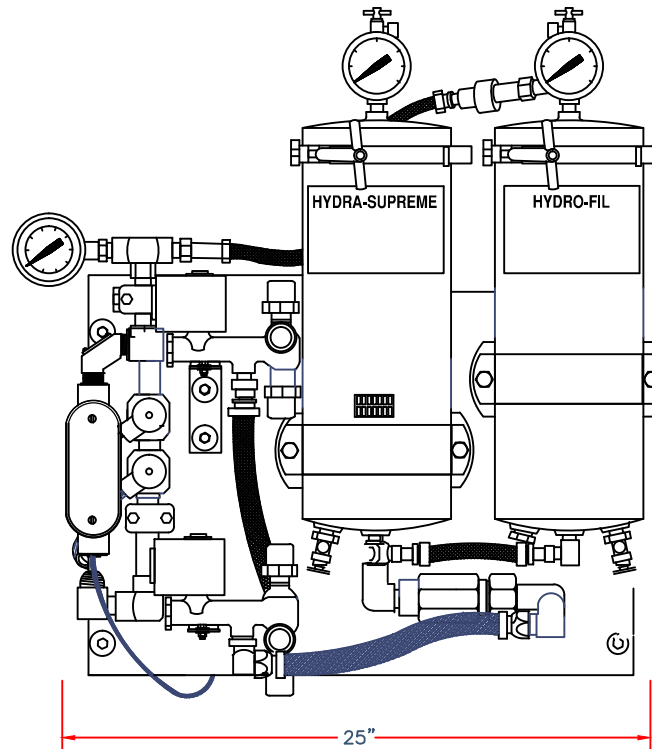

ANGELUS R-5 LAYOUT

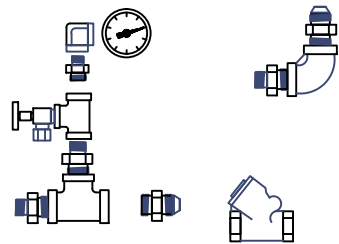

**PUMP FITTINGS
(SHIPPED LOOSE)**

DWG. TITLE ASCR5 FILTRATION SYSTEM AND PUMP				HTI FILTRATION		830-011 E WITH MOTOR/PUMP																					
PROJECT DESCRIPTION ANGELUS F029H614 ABH4						<table border="1"> <tr> <td>E</td> <td>08/20/08</td> <td>SP</td> <td>SP</td> <td>ADD CHECK VALVE</td> </tr> <tr> <td>D</td> <td>09/02/04</td> <td>SP</td> <td>SP</td> <td>SHOW PUMP FITTINGS</td> </tr> <tr> <td>C</td> <td>03/01/04</td> <td>SP</td> <td>SP</td> <td>CHANGE FLOW SENSOR</td> </tr> <tr> <td>REV.</td> <td>DATE:</td> <td>DRWN BY</td> <td>CHKD BY</td> <td>DESCRIPTION</td> </tr> </table>				E	08/20/08	SP	SP	ADD CHECK VALVE	D	09/02/04	SP	SP	SHOW PUMP FITTINGS	C	03/01/04	SP	SP	CHANGE FLOW SENSOR	REV.	DATE:	DRWN BY
E	08/20/08	SP	SP	ADD CHECK VALVE																							
D	09/02/04	SP	SP	SHOW PUMP FITTINGS																							
C	03/01/04	SP	SP	CHANGE FLOW SENSOR																							
REV.	DATE:	DRWN BY	CHKD BY	DESCRIPTION																							
JOB NO.	DRAWING NO.	REVISION	CUST. CONTR. NO.	11820 WESTERN AVE. STANTON, CA 90680		CUSTOMER ANGELUS SANITARY CAN																					
-	830-011 E	E	-																								