

OPERATOR MANUAL
HYDRA-SUPREME FLUID SCRUBBING SYSTEM
MODEL 810-051.2
CANFORMING EQUIPMENT APPLICATION

INTRODUCTION:

Hydra-Supreme fluid scrubbing systems are high performance industrial filters designed to remove particulate, oxidized oil and water from hydraulic and lubricating fluid systems. This particular model, 810-051.2, is specifically designed for cleaning the lubricating oil in two-piece aluminum and steel can making systems. The system is manufactured from durable, corrosion resistant materials and is designed for constant, uninterrupted use without immediate supervision. This system will assure the required high degree of fluid purity with an absolute minimum of maintenance and service requirements.

SYSTEM OPERATION:

The Hydra-Supreme fluid scrubbing system utilizes a patented cellulose element to clean the working fluid of accumulated debris. The cleaning process utilizes three interlocking processes to remove solid particulate, varnish and water-based coolant from the oil. By combining barrier filtration, chromatographic separation, and absorption, all three of the listed contaminants can be removed from the oil simultaneously and efficiently. As the filter traps the contaminants, it builds up resistance and the pressure increases at 60 PSI/4.1 bar as the pressure switch contact activates to send a signal to the operator's console indicating the need to change the filter.

The proper function of the filter requires the correct placement of the inlet and return lines, the correct flow volume, delivery, and pressure. The transfer lines should pull fluid from the reservoir and return it to a location at least 24" away to prevent recirculating the same oil repeatedly. Oil removal and return from the reservoir is highly preferred over using pressurized sources for the oil. The rotary ring gear pump provides extremely smooth fluid delivery to prevent pulsations that can dislodge debris from the filter element. Combining smooth delivery with the proper flow volume assures high trapping efficiency and long element life. Under normal conditions, your Hydra-Supreme element should last 2-4 months before requiring changeout. The filtration efficiency begins to drop off sharply as the pressure rises above 60 PSI and the filter element will begin shedding debris back into the oil above 75 PSI.

SYSTEM PRESSURE:

Pressure readings will vary with the viscosity of the oil used, the operating temperature of the reservoir, and the amount of debris absorbed by the filter.

Typical start-up pressures using 750 SUS oil at 100⁰ F is 12-18 PSI on 60 HZ machines; 10-12 PSI on 50 HZ electrical systems.

Typical change out point is 60 PSI or a 50-PSI increase in original operating pressure, but not to exceed 75 PSI.

Pump output pressure is controlled by an external relief valve that is factory set to open at 65 PSI. ***Do not change this valve.*** Using a higher relief pressure valve can cause dangerous pressures and will not improve the filter efficiency or life.

Under no circumstance should your unit ever exceed 90 PSI. Should this occur, shut down the system and contact the HTI Technical Service Department at (719) 490-8800 or sales@htifiltration.com for assistance.

SYSTEM LOCATION:

Although the Hydra-Supreme system uses a self-priming pump, it is important to keep the filter as close to the reservoir as possible. The suction line should be less than 8' long and use ¾" fittings throughout the delivery line.

Set the filtration system on a solid level surface. Allow a minimum of 24" of frontal clearance for service access. Filter system should be kept free of moisture and under 140° F.

PLUMBING:

The suction and return lines come equipped with 3/4" JIC 37 degree hose fittings. A maximum hose length of 8' is recommended as is the use of sealing caulk or tape on all threaded fittings.

Ball valves can be installed on both connections for easy shut-off during installation, adjustment, or service.

ELECTRICAL:

The filter power system should be independent of the machine power as the oil scrubbing system should run continuously for efficient contaminant control.

The motor for this model is a .37 Kw 50 /60 Hz - 180-460 V 3 phase that draws 1.8 FLA
The pressure switch operates with 9-36 VDC power.

INITIAL START-UP PROCEDURE

Upon completion of the electrical and hydraulic connections, the Hydra-Supreme is ready for start-up. The pressure relief valve is factory set for a maximum operating pressure of 60-65 PSI. If your unit exceeds this level during any phase of operation, turn it off immediately and contact HTI Filtration for instructions.

Open all valves on the inlet and return lines.

Crack open the bleed valve on the top of the canister.

Turn on the pump.

Close the bleed valve as oil starts to flow from it.

Check for fluid leaks before leaving the area.

Field Adjustment of Pressure Switch

Before changing any settings on an HTI System, run the body maker until the oil is at the normal operating temperature (typically between 100-120°F). This normally takes several hours because of the relatively low flow volume and high metal mass of the components.

1. Turn filter system on and allow oil to fill the canister while venting the air through the bleed cock on the canister lid.
2. As soon as fluid flows from bleed cock, close and secure.
3. Slowly close the outlet hose ball valve until the system pressure is at 55-58 PSI (as shown on the pressure gauge atop the canister.)
4. Remove clear cover of pressure switch. Turn the yellow locking ring from “lock” to “unlock”. Adjust the set point by rotating the SET ring until the LED illuminates. The RESET ring should be set 5 PSI below the level of the SET ring. Rotate the locking ring back to the “lock” position. Place the cover back on the switch and open the ball valve to restore full flow to the filter. The filter pump and safety relief valve will start to bypass oil internally at 60 PSI, so setting the pressure sensor higher will defeat the purpose of informing the operator of a pending filter change out.

FILTER ELEMENT REPLACEMENT

THIS SYSTEM USES THE 800-026 REPLACEMENT ELEMENT

- Step 1: Turn off the Filter System. It is not necessary to turn off the host machine to service the Hydra-Supreme filter.
- Step 2: Turn off the pump and position the drain hose over a bucket. Next, open the drain valve on the bottom of the canister and then open the bleed cock on the top of the lid. Drained oil can later be used to refill the canister.
- Step 3: Remove the lid clamp by loosening the two bolts that hold it in place. Examine the canister O-ring for cracks and wear spots. Replace the canister lid seal if it was leaking, or if it shows signs of wear.
- Step 5: Unscrew the “T” handle assembly that holds the filter in place. The cup seal on the handle assembly should be smooth and free of rough spots or tears. Replacement seals are available.
- Step 6: Slice open the end of the plastic bag holding the new element. Remove the new element and set in a clean area. Lift used element off of center post, using the filter bale and slide it into plastic bag or into a bucket.
- Step 7: Make sure the O-ring is in place at the bottom of the filter. Slide new element over The center post. Insert the threaded “T” handle and turn CW until the filter is firmly seated.
- Step 8: Close drain cock and refill canister with as much of the drained oil that will fit.
- Step 9: Put the O-ring back on the canister lip, replace lid, install the clamp and tighten it.
- Step 10: Start the pump motor and allow air to bleed out through bleed cock on top of canister.
Close bleed cock when fluid starts to come out. Wipe up any spilled oil and check for leaks.

IMPORTANT NOTE: Do not leave canister until you have visually verified that it is not leaking. A slow leak will eventually drain the gearbox reservoir.

The spent filter must be drained free of oil before disposal of the filter. This is typically done by allowing the filter to drain for 24 hours.

CAUTION

Some hydrocarbon oils are not suitable for extended use after they have been mixed with water. These non-hydrolytically stable lubricants tend to precipitate out their additives which are captured by the Hydra-Supreme filter element. These oils look acceptable, but no longer have the original anti-wear and anti-oxidization characteristics of new oil.

HTI Filtration recommends that you use a premium grade lubricant whenever you have an on-going water contamination problem and that you consult your lubricant supplier for specific information on your specified oil.



HTI Filtration Inc.

7716 Gary Watson Pt. • Colorado Springs, CO 80915 • 719.490.8800 • sales@htifiltration.com

May 11, 2021

**Product Safety Bulletin
Lid Clamp Tightening Instructions
HTI Part # 540-010 & 540-012**

HTI Filtration continuously monitors our products in the field to improve our equipment capabilities and safety. We have been informed that some canisters are developing leaks at the lid seal area after being in service for several years. After consulting with the canister manufacturer, it has been determined that this can be caused by overtightening the stamped steel 2-piece lid clamps, HTI Part # 540-012.

To prevent distortion of the canister body and lid flanges, please follow the following torque specifications for the older 540-012 lid clamps and the newer 540-010 V-Band clamps.

540-012 – Alternate tightening: from one side to the other until clamps are fully nested into each other and you have achieved an even pull down of the cover. **DO NOT OVER TIGHTEN.**



540-010 – Hand tighten to a maximum of 30 Ft L\Lbs.



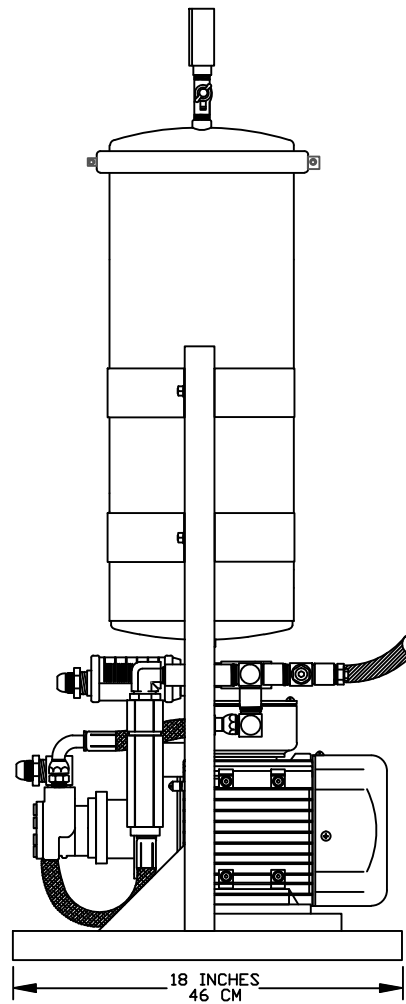
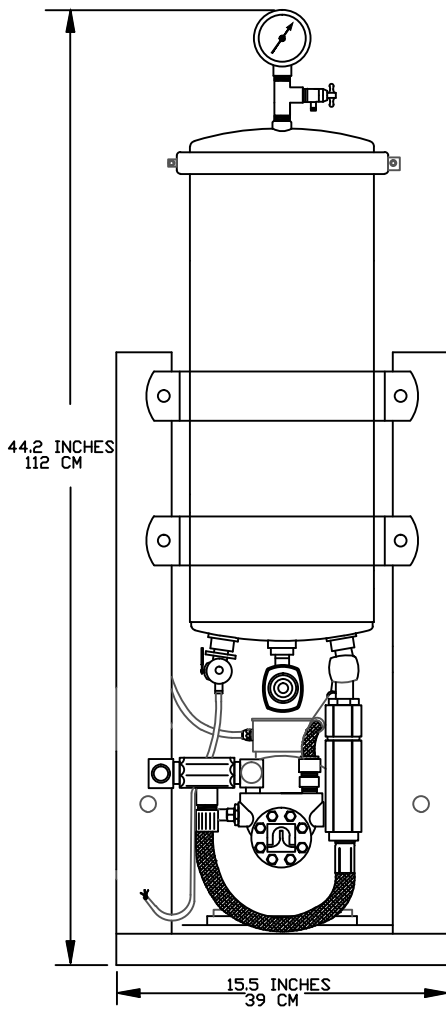
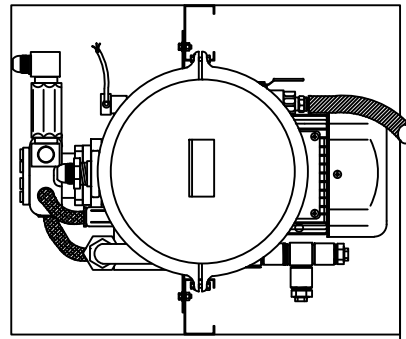

DWG. TITLE BODYMAKER FILTRATION SIZE		HTI FILTRATION		810-051.2 CE/IEC					
PROJECT DESCRIPTION 810-051.2 BODYMAKER OIL FILTER				7716 Gary Watson Pt. Colorado Springs CO 80915		0	07/27/17	SP	SP
DRAWING NO. 810051.2DIM	REVISION 0	CUST. CONTR. NO. -			REV.	DATE:	DRWN BY	CHKD BY	DESCRIPTION
			CUSTOMER						

MOTOR CIRCUIT

16-4 SEEDW CABLE 4 M LENGTH

LOW VOLTAGE CABLE

22 AWG BLACK PUR, 5 M length

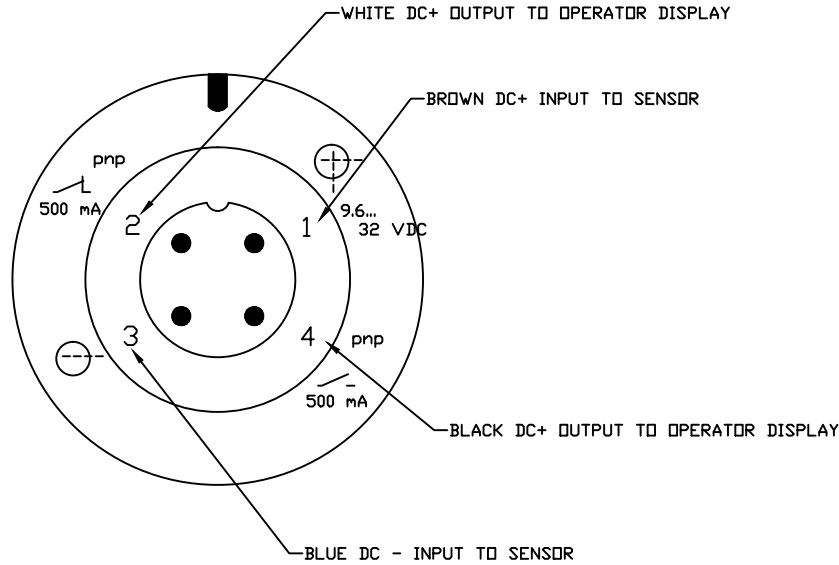

FAN
END

BLACK RED WHITE

L1	L2	L3
W1	VI	U1
○	○	○
T3	T2	T1

W5	V5	U2
○	○	○
T6&9	T5&8	T4&7

SHAFT
END

M.G.M.
SMX 71

WARNING LIGHT CIRCUIT

M.G.M. MOTORS

DWG. TITLE 810-051.2 WIRING		HTI FILTRATION		810-051.2 WIRING SCHEMATIC																					
PROJECT DESCRIPTION BODYMAKER METRIC 3 PHASE FILTER		7716 Gary Watson Pt. Colorado Springs CO 80915		<table border="1"> <tr> <td>-</td> <td>-</td> <td>-</td> <td>-</td> <td>-</td> </tr> <tr> <td>0</td> <td>08-15-12</td> <td>SP</td> <td>SP</td> <td>ORIGINAL ISSUE</td> </tr> <tr> <td>REV.</td> <td>DATE:</td> <td>DRWN BY</td> <td>CHKD BY</td> <td>DESCRIPTION</td> </tr> <tr> <td colspan="5">CUSTOMER</td> </tr> </table>		-	-	-	-	-	0	08-15-12	SP	SP	ORIGINAL ISSUE	REV.	DATE:	DRWN BY	CHKD BY	DESCRIPTION	CUSTOMER				
-	-	-	-	-																					
0	08-15-12	SP	SP	ORIGINAL ISSUE																					
REV.	DATE:	DRWN BY	CHKD BY	DESCRIPTION																					
CUSTOMER																									
DRAWING NO. 810-051.2 WS	REVISION 0	CUST. CONTR. NO. -		-																					

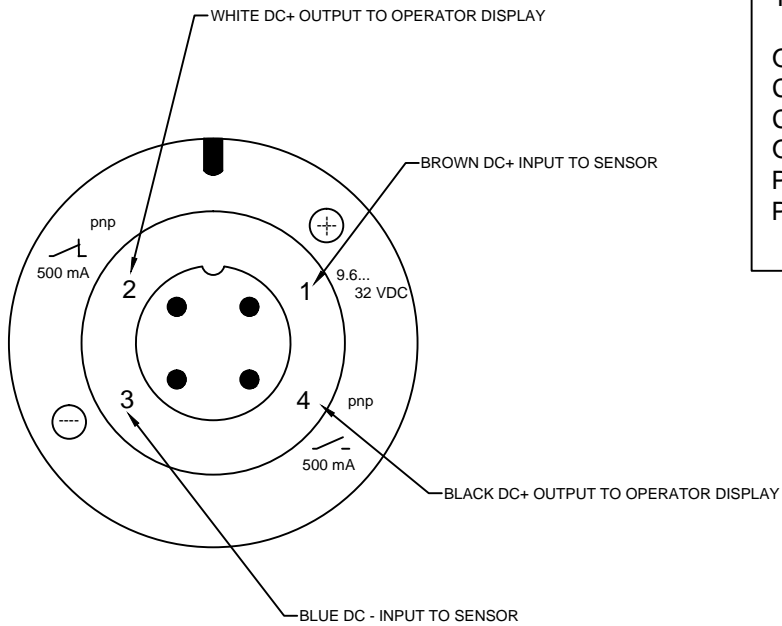

TECHNICAL DATA -	
OPERATING VOLTAGE -	9.6 TO 32 VDC
CURRENT RATING (mA) -	500
CURRENT CONSUMPTION -	<25
OPERATING TEMPERATURE -	-25 TO 80 C
PROTECTION -	IP 67 / III
PRESSURE RANGE-	0...10 BAR 0...145 PSI

NOTE:
 USE 620-005 RIGHT ANGLE CONNECTOR
 M12 micro DC (4 pin) 5m 22 AWG, Black
 PUR jacket

USE 620-006 CLEAR COVER

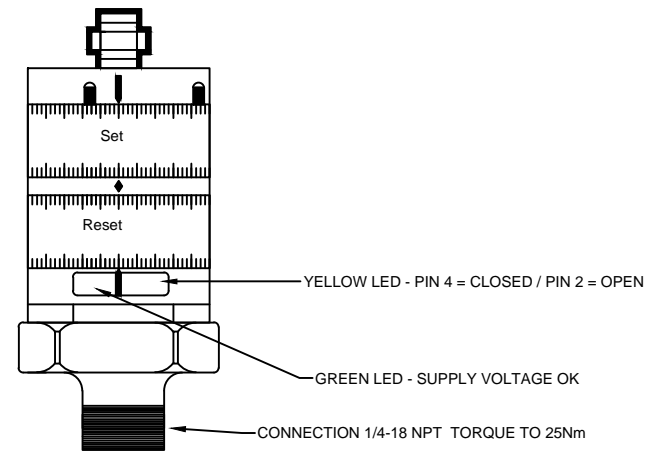

DWG. TITLE PRESSURE SWITCH ILLUSTRATION				HTI FILTRATION							
PROJECT DESCRIPTION PRESSURE SWITCH 620-004				7716 Gary Watson Pt. Colorado Springs CO 80915		0	08-10-12	SP	SP	ORIGINAL ISSUE	
JOB NO.	DRAWING NO.	REVISION	CUST. CONTR. NO.			REV.	DATE:	DRWN BY	CHKD BY	DESCRIPTION	
-	620-004		-			CUSTOMER					

TROUBLESHOOTING GUIDE

HTI Filtration Model 810-051.2

Please note: All pressure readings are to be taken with the system at normal operating temperatures.

SYMPTOM	CAUSE	CORRECTIVE ACTION
ERRATIC FLOW RATE, BUBBLES IN OIL STREAM	AIR LEAK IN INLET FITTING	CHECK FITTINGS FOR TIGHTNESS AND INTEGRITY
	CUT OR PINCHED FEED HOSE	VISUALLY CHECK INLET HOSE FOR DEFECTS
	LOW FLUID LEVEL	CHECK FLUID LEVEL IN RESERVOIR
EXCESSIVE VACUUM (ABOVE 20")	INLET PIPING RESTRICTION	CHECK INLET HOSE FOR RESTRICTION OR BLOCKAGE
	OIL TOO THICK (OVER 900 SUS @100°F)	CHECK OIL VISCOSITY (MAX: 900 SUS @100°F)
	OIL RUNS TOO COLD-OIL DOESN'T GET OVER 80' F.	CHANGE TO LIGHTER GRADE OIL
LOW FLOW RATE WITH LOW PRESSURE	OIL LEAKING OUT OF SYSTEM	CHECK FOR LEAKS IN PLUMBING
	INSUFFICIENT MOTOR POWER	CHECK FOR PROPER PUMP VOLTAGE AND ROTATION
	OIL BYPASSING THROUGH RELIEF VALVE	TURN SYSTEM OFF TO RESEAT RELIEF VALVE
LOW FLOW RATE WITH HIGH PRESSURE	LOADED FILTER	REPLACE FILTER ELEMENT
	RESTRICTED OUTLET LINES	CHECK AND CLEAR RETURN LINES
EXCESSIVE PRESSURE	RELIEF VALVE NOT OPENING	REPLACE VALVE
SHORT FILTER LIFE	EXCESSIVE WATER IN OIL	BLEED OFF WATER IN RESERVOIR, FIX LEAK
	EXCESSIVE SLUDGE IN OIL	CLEAN OUT RESERVOIR
LEAK AT LID CLAMP	CUT OR ERODED SEAL	REPLACE AS NEEDED
WARNING LIGHT COMES ON BELOW 60 PSI OR ABOVE 65 PSI	PRESSURE SWITCH SET WRONG	RESET PRESSURE SWITCH

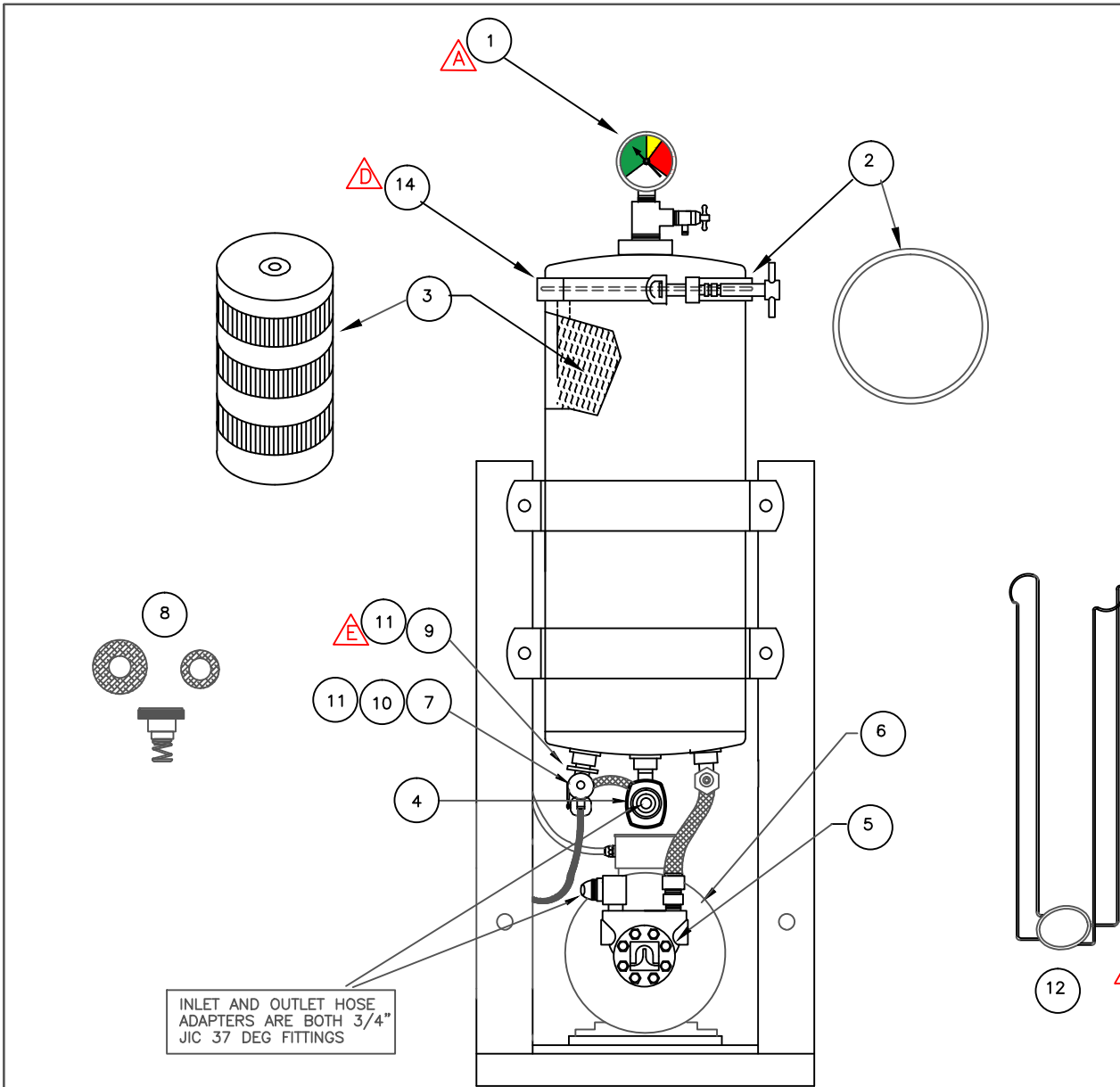

REPLACEMENT PARTS			
REV	ITEM NO.	DESCRIPTION	HTI NO
A	1	PRESSURE GAUGE	610-024
	2	LID SEAL	450-002
	3	FILTER ELEMENT	800-026
	4	FLOW METER	630-006
	5	MOTOR 3 PHASE 50/60 HZ 3 Ph	780-024
	6	1.5 GPM / 5.25 LPM PUMP	770-024
	7	PRESSURE SWITCH	620-004
	8	PUMP REBUILD KIT - VITON	460-057
A	9	PRESSURE RELIEF VALVE	430-082
	10	PRESSURE SWITCH RT ANGLE CABLE	620-005
	11	PRESSURE SWITCH CLEAR COVER	620-006
C	12	ELEMENT LIFTER	530-008
D	13	2 PIECE LID CLAMP-OBSOLETE	-
D	14	V-BAND LID CLAMP	540-010
E	15	PRESSURE RELIEF VALVE	430-073

INLET AND OUTLET HOSE ADAPTERS ARE BOTH 3/4" JIC 37 DEG FITTINGS

DWG. TITLE		HTI FILTRATION			
810-051.2 BODY MAKER FILTER		7716 Gary Watson Pt. Colorado Springs CO 80915			
PROJECT DESCRIPTION					
METRIC MOTOR BODYMAKER OIL FILTER					
DRAWING NO.	REVISION	CUST. CONTR. NO.			
810-051.2PL	D	-			
E	06-10-22	SP	SP	CHANGE RELIEF VALVE	
D	12-22-20	SP	SP	ADD V BAND LID CLAMP	
C	10-30-20	SP	SP	REINSTATE ELEMENT LIFTER	
B	01-12-18	SP	SP	REMOVE ELEMENT LIFTER	
REV.	DATE:	DRWN BY	CHKD BY	DESCRIPTION	
				CUSTOMER -	



HTI FILTRATION

7716 Gary Watson Pt. • Colorado Springs, CO 80915 • 719.490.8800 • sales@htifiltration.com

STANDARD WARRANTY

This filter system was inspected before shipment from our plant. To the original purchaser of this system, HTI Filtration warrants its products free from defects in material and workmanship for a period of one (1) year from date of purchase.

HTI Filtration makes no other express warranty and excludes (and buyer waives) any and all implied warranties including, without limitation to, implied warranties in connection with the design, sale, merchantability or fitness of the goods for any particular use or purpose.

In order for any claim under this warranty to be valid, HTI Filtration must receive notice in writing from the buyer within a reasonable time period, not to exceed thirty (30) calendar days after any defect is discovered. The claim must include a detailed report of the conditions of use at the time of discovery of defect. Parts which fail or become defective during the warranty period (except as a result of freezing, melting, improper installation, use or care), shall be replaced or repaired at HTI Filtration's option at no charge within 90 days of the receipt of the defective part, barring unforeseen delays. HTI Filtration shall in no event be responsible for the repairs made by others without the express written permission and consent of HTI Filtration.

To obtain warranty replacement or repairs, defective components or parts should be returned, freight prepaid, to place of purchase or nearest authorized service center. HTI Filtration shall not be responsible for cartage, removal and/or reinstallation labor or any other such costs incurred in obtaining warranty replacements. In no event shall HTI Filtration be responsible for any incidental or consequential damage, whether foreseeable or not and whether or not such damage occurs, or is discovered before or after repair or replacement.

The forgoing warranty does not apply to wear components, seals or filtration elements.

This warranty extends only to the original buyer and HTI Filtration makes no other warranty, expressed or implied, to other persons or entities. If buyer makes any warranty or representation inconsistent with or in addition to the warranty stated hereinabove, the buyer shall, at their own expense, defend and hold HTI Filtration harmless from any claim thereon of any nature whatsoever.