

# OPERATORS MANUAL

## HYDRA-CLEAN FLUID SCRUBBING SYSTEM

830-002.5

Angelus F029H614AAQ5

### INTRODUCTION:

Hydra-Clean fluid scrubbing systems are high performance industrial filters designed to remove particulate and water from hydraulic and lubricating oil systems. Manufactured from durable, corrosion resistant materials, they are designed for constant, uninterrupted use without immediate supervision. The Hydra-Clean 830-002.5 system utilizes two elements in series to remove water, and then particulate from the working fluid. This system ensures a high degree of fluid purity with an absolute minimum of maintenance and service requirements.

This operating manual is designed to provide you with the basic information to economically and efficiently service your fluid scrubbing system. HTI Filtration welcomes your comments and our technical service staff is available to assist you in applying our equipment to solve your fluid purity problems.

### SYSTEM OPERATION:

The Hydra-Clean filtration system uses two separate filtration elements in series to progressively clean the working fluid. Fluid is drawn from the reservoir up through a check valve by a rotary pump. The fluid is then pushed through the flow sensing and pressure switch assembly into the water removal bag element where the free and emulsified moisture is absorbed. The partially cleaned solution passes through the axial flow; media filter where both soft and hard particulate contamination are removed. The filtered oil then passes through a solenoid operated selector valve and back into the seamer or the pressurized lubrication system reservoir. If the contamination level in the oil is high, or if the filters are nearing capacity, several passes through the system may be required for total cleansing of the oil.

The gravity check valve at the pump inlet ensures adequate oil supply to wet the pump during start-up and prevents drain back when the system is shut-off. The vacuum gauge indicates the resistance to flow and has a manual bleed cock that should be cracked open for safety relief during initial start-up in case the motor is rotating backwards. Typical vacuum readings are from 3 – 10". The bleed cock on the outlet elbow of the pump is to relieve entrapped air from the pump chamber so that oil can be drawn in to restore pump suction.

An internal relief valve that is factory set at 90-100 PSI controls pump output pressure. We do not recommend changing this setting. Removing the acorn nut without proper tools may result in an intake air leak that will require a new gasket to correct.

Oil temperature is displayed by a digital gauge with high and low temperature alarm

settings available. The pump output and service life of the two filter elements are monitored by a series of 1 flow sensor and 2 pressure switches. The flow switch monitors the volume of oil being pumped through the system. It is used to indicate when flow through the system has dropped below the minimum level required for adequate oil cleansing and replenishment of the seamer lubrication pump reservoir. Adequate flow is indicated by the illumination of the indicator lamp inside the flow switch. If flow falls below .25 GPM the light will go out and a warning will appear on the operator panel. The flow switch is factory set at .22-.25 GPM (.83 -.95 l/min) and field adjustment is not advised. A pair of stepped pressure switches monitors the system pressure. The initial switch activates the amber "*Check Filter*" light on the main panel. The secondary pressure switch illuminates the "*Change Filter*" light. Pressure switch settings are field adjustable and must be set to reflect the type of oil used and operating temperatures the filter is working with to receive maximum use from the filters. The initial (right hand) switch typically activates at 15 PSI (1 Bar) above the start-up pressure and the Change Filter light illuminates at 10 PSI (.66 Bar) above that setting. Complete field adjustment instructions are included in this manual.

The selector valve is operated by remote sensing switches and timers in the seamer, which vary depending on which options are selected at the time of order. The maximum line resistance pressure on the diverter pump should be less than 25 PSI (1.75 Bar) when the valve is activated.

#### SYSTEM PRESSURES:

Pressure readings will vary widely with the oil viscosity, seamer operating temperature and temperature of the oil entering the filtration system. It is also not unusual for system pressures to rise substantially over normal levels when re-starting a system that has been left off for several days or when changing particulate filters. Typically, the system will return to normal levels after 45-60 minutes as the warm oil from the seamer flushes out the cooler oil from the filter elements and the filtration passages in the new element open under pressure. A timed delay in the pressure switch alarms has been programmed in for these reasons. In cold climates it may be necessary to heat the Hydra-Supreme axial filter canister to maintain the desired 90-100°F operating temperature.

#### Factory Set Warning Pressures and Change Out Pressures

Using 750 SUS (40 Wt.) lubricant @ 75°F

Warning Switch - 65 PSI Change Filter Switch - 75 PSI

Typical bag element change out is 10 -15 PSI increase over new element pressure. All measurements should be made when system is fully warmed to operating pressure.

### OIL SELECTION INFORMATION:

HTI Filtration has tested many oils commonly used in seamers. While we do not recommend a specific brand or type of oil we do recommend that you use a high quality oil that has good hydrolytic stability. That is, an oil that can be exposed to water repeatedly and dried without deleting or precipitating the additive package.

The viscosity of the oil plays a major role in determining the operating pressure of the system. A 40 Wt. oil rated at 750 SUS at 100°F is actually 2,000 SUS at 75° F, a 260% increase in viscosity! Even small temperature changes can result in significant pressure variations in the system. It is not uncommon for a cold filter system to read higher pressures in the morning and then have them drop off as the system components warm over several hours to an even operating temperature.

### Field Adjustment of Pressure Switches

Before changing any settings on a Hydra-Clean Fluid Conditioning System, run the seamer and filter until the oil is at the normal operating temperature (typically between 75-100°F). This normally takes several hours because of the relatively low flow volume and high metal mass of the components.

NOTE: Do not attempt to reduce or increase the operating pressure by adjusting the internal pressure relief valve on the pump. This safety devise has been set and locked into place at the factory. Attempting to adjust the pressure setting screw can jam the relief valve and prevent proper movement. Improperly removing the acorn nut may also result in air leaking into the system, which will require frequent system bleeding until the acorn nut seal is replaced.

1. Turn filter system on and allow oil to fill both canisters while venting the air through the bleed cocks on the canister lids.
2. As soon as fluid flows from bleed cock, close and secure.
3. Allow filter system to run for 60-120 minutes to flush cold oil out of the filters and bring entire system up to operating temperature. Note the operating pressures of the filters.

4. Slowly close the 1/4" ball valve at the base of the Hydra-Supreme (left hand side) canister until the system pressure is 10-12 PSI higher than the reading in Step 3.
5. Remove cover of warning pressure switch (right hand switch) and adjust it by rotating the SET ring until LED illuminates. The RESET ring should be set 5 PSI below the level of the SET ring. Place the cover back on the switch
6. Increase system pressure by 5 PSI by further closing the valve and then adjust the maximum pressure switch (left-hand switch) the same way as in Step 5.
7. Open the ball valve to relieve the pressure build-up and allow the system to run for 10-15 minutes before recording the pressures for future reference.

#### SYSTEM LOCATION:

Although the Hydra-Clean system uses a self-priming pump, it is advisable to keep the filter below, and as close to the reservoir as possible. A suction line vacuum condition no greater than 20"hg should be experienced during start-up or normal operation. Pump damage will occur at vacuum levels above 24" hg.

Where the filter is remotely mounted from the seamer, it may require a booster pump at the seamer reservoir to deliver the oil to the filter pump. The booster pump should deliver a maximum of 15-PSI pressure. Remote mounted filters will also experience higher-pressure readings due to the increased return line resistance. Pre-set booster pumps are available through PS-Angelus.

Set the filtration system cabinet on a solid, level surface. Allow a minimum of 24" of frontal clearance for service access. Locate filter away from sources of moisture and heat, filter system must be kept below 140°F, and be protected from moisture.

#### PLUMBING:

Inlet and return tubing should be 3/4" with a preferred maximum distance of 20'.

The two return ports utilize 3/4" JIC fittings; flow selection is determined by remote activation of the solenoid valve from the main control panel. Outlet lines to the main reservoir and lubricating system should be 3/4" or larger with a preferred maximum length of 20'-0". Ball valves can be installed at both reservoir connections for easy shut off during installation or service.

### ELECTRICAL:

The motor utilizes 3 phase, 50/60 Hz power with a number of voltage options. Please check the nameplate on your motor if you are unsure of your power type.

The solenoid coil, pressure switches and flow sensor come standard using 24 VDC operating power. 110-volt power is optional for the solenoid.

The power source for the filter should be independent of the basic machine control, as the oil filtration system should run continuously for efficient contaminant control.

### INITIAL START-UP PROCEDURE

Upon completion of the electrical and hydraulic connections, the Hydra-Clean system is ready for start-up. The 830-002.5 is factory adjusted to perform with a fluid viscosity of 750 SUS (164 C ST at 40°C) at 75°F. To use different viscosity fluids or to run at different temperatures, please make the recommended changes to the switch settings. See the previous section in this manual for further information on adjusting the pressure settings.

### FILTER SYSTEM START-UP:

Turn the electrical power on to start the gear pump. Make sure the inlet and return lines to the reservoir are free of restriction and all valves are open. Crack open the bleed cocks at the top of both canisters. As soon as fluid starts to flow from the bleed hole, close the cock securely and wipe the fluid from the canister top. Let the system warm up to typical operating temperature.

When initially starting the Hydra-Clean system, air may enter the plumbing lines in sufficient quantity to keep the pump from priming itself or create a false reading in the oil flow sensor. Should this occur, you must bleed off this trapped air by opening the bleed cock located at the pump outlet elbow just above the union.

**NOTE:** Your Hydra-Clean fluid scrubbing system should have no occasion to exceed 95 PSI when properly installed and using the recommended type of fluid. Should a pressure condition exceed the recommended maximum, immediately shut off the filtering system and contact HTI Filtration for assistance.

## **FILTER ELEMENT REPLACEMENT**

### **BAG ELEMENT:**

A new bag element should be installed after the system has been in service for 6 months or shows a 10 -15 PSI pressure increase.

- Step 1: Turn off the Filter System. It is not necessary to turn off the seamer to service the filter.
- Step 2: Open the drain cock at the bottom of the bag (right hand) canister, then open the bleed cock at the top. The 3/8" hose can be used to direct the oil to a container where it can be poured back into the canister for re-use.
- Step 3: Remove the canister clamp ring and lift off the lid.
- Step 4: Examine the "O" ring for wear, replace this ring if it shows signs of wear or if the canister was leaking. A spare "O" ring is shipped with every system.
- Step 5: Slowly lift the bag out by the strap allowing the captured oil to drain back into the canister. Hang the bag over a receptacle if you want to reclaim the approximately 3 cups of oil entrained in the bag.
- Step 6: Slice open the plastic bag holding the new bag. Carefully remove the bag and straighten to its full length. Slide the new bag into the colander using the fabric strap to push the metal bag ring down firmly onto the seat. Do not use the fabric strips inside the bag to seat the filter or they will tear off.
- Step 7: Close the drain cock and fill the bag with the drained oil captured in Step 2.
- Step 8: Put the "O" ring back on the canister lip, replace the lid, clamp and tighten.
- Step 9: Start the motor and allow the air to escape through the bleed cock. Close the cock when fluid starts to come out, wipe off the unit, and check for leaks.

### **AXIAL ELEMENT:**

- Step 1: Turn off the Filter System. It is not necessary to turn off the seamer to service the Hydra-Supreme filter.

- Step 2: Open the drain cock on the bottom of the lid, then open the bleed cock on the top of the canister. The 3/8" ID hose can be used to direct the draining oil to a receptacle. Drained oil can later be used to refill the canister.
- Step 3: Remove the canister clamp ring and lift off the canister lid.
- Step 4: Examine the canister "O" ring for cracks and wear spots. If the canister lid seal was leaking, or if the "O" ring shows signs of wear, replace the ring.
- Step 5: Unscrew the "T" handle assembly that holds the filter in place. The cup seal on the handle assembly should be smooth and free of rough spots or tears. Replacement seals are available.
- Step 6: Slice open the end of the plastic bag holding the new element. Remove the new element and set in a clean area. Lift used element off of center post and slide it into plastic bag.
- Step 7: Slide new element over the center post. Make sure the pull strap is at the top. Secure the element with the "T" handle.
- Step 8: Close drain cock and refill canister with oil.
- Step 9: Put the "O" ring back on the canister lip, replace lid, clamp and tighten.
- Step 10: Start the pump motor and allow air to bleed out through bleed cock on top of canister. Close bleed cock when fluid starts to come out. Wipe off unit and check for leaks.

### **CAUTION**

Some hydrocarbon oils are not suitable for extended use after they have been mixed with water. These non-hydrolytically stable lubricants tend to precipitate out their additives, which are captured by the Hydra-Supreme axial filter element. These oils look acceptable, but no longer have the original anti-wear and anti-oxidization characteristics of new oil.

HTI Filtration recommends that you use a premium grade lubricant whenever you have an on-going water contamination problem and that you consult your lubricant supplier for specific information on your specified oil.

CABINET SPECIFICATION  
 MATERIAL - #14 GA TYPE 302-304  
 FINISH - BRUSHED  
 SPECIFICATION- NEMA4R

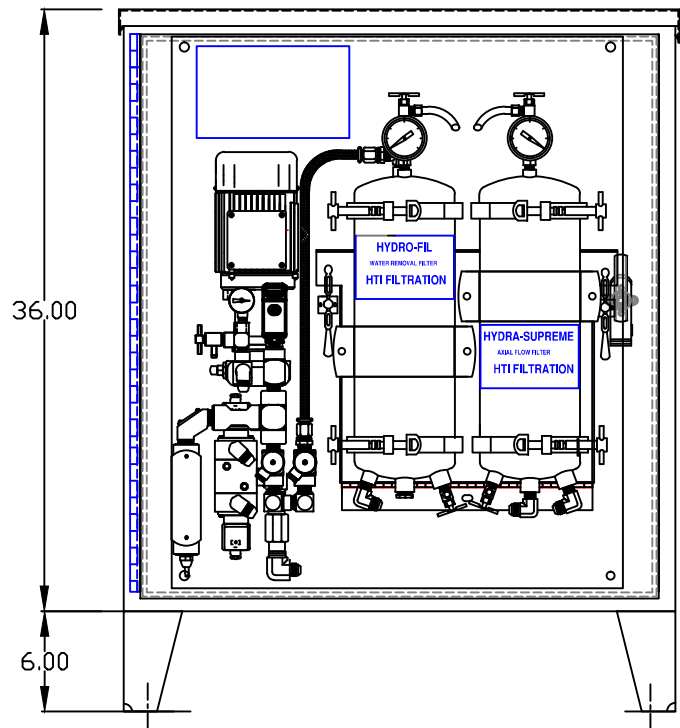
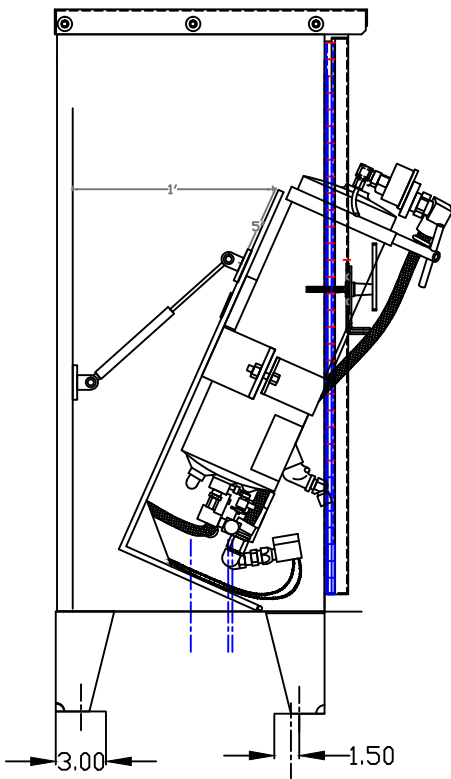
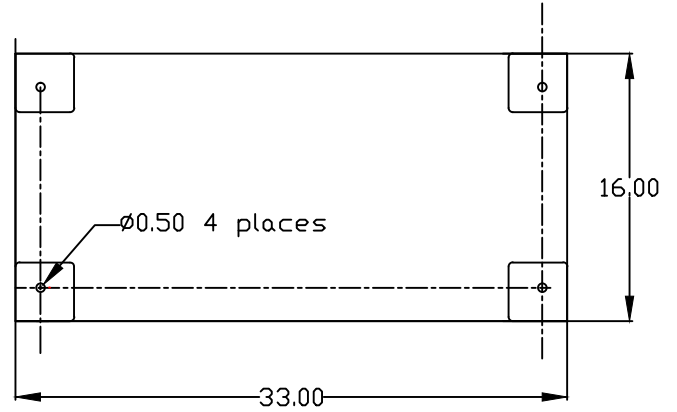

DWG. TITLE 830-002.7				HTI INC.		830-002.5				
PROJECT DESCRIPTION ANGELUS F029H614 CABINET MOUNT				7716 GARY WATSON PT COLORADO SPRINGS COLORADO, USA 80915		A	4-15-2022	SP	SP	ADD DIGITAL TEMP
JOB NO.	DRAWING NO.	REVISION	CUST. CONTR. NO.			0	8/17/10	SP	SP	FIRST ISSUE
-	830-002.5	A	-	CUSTOMER		REV.	DATE:	DRWN BY	CHKD BY	DESCRIPTION



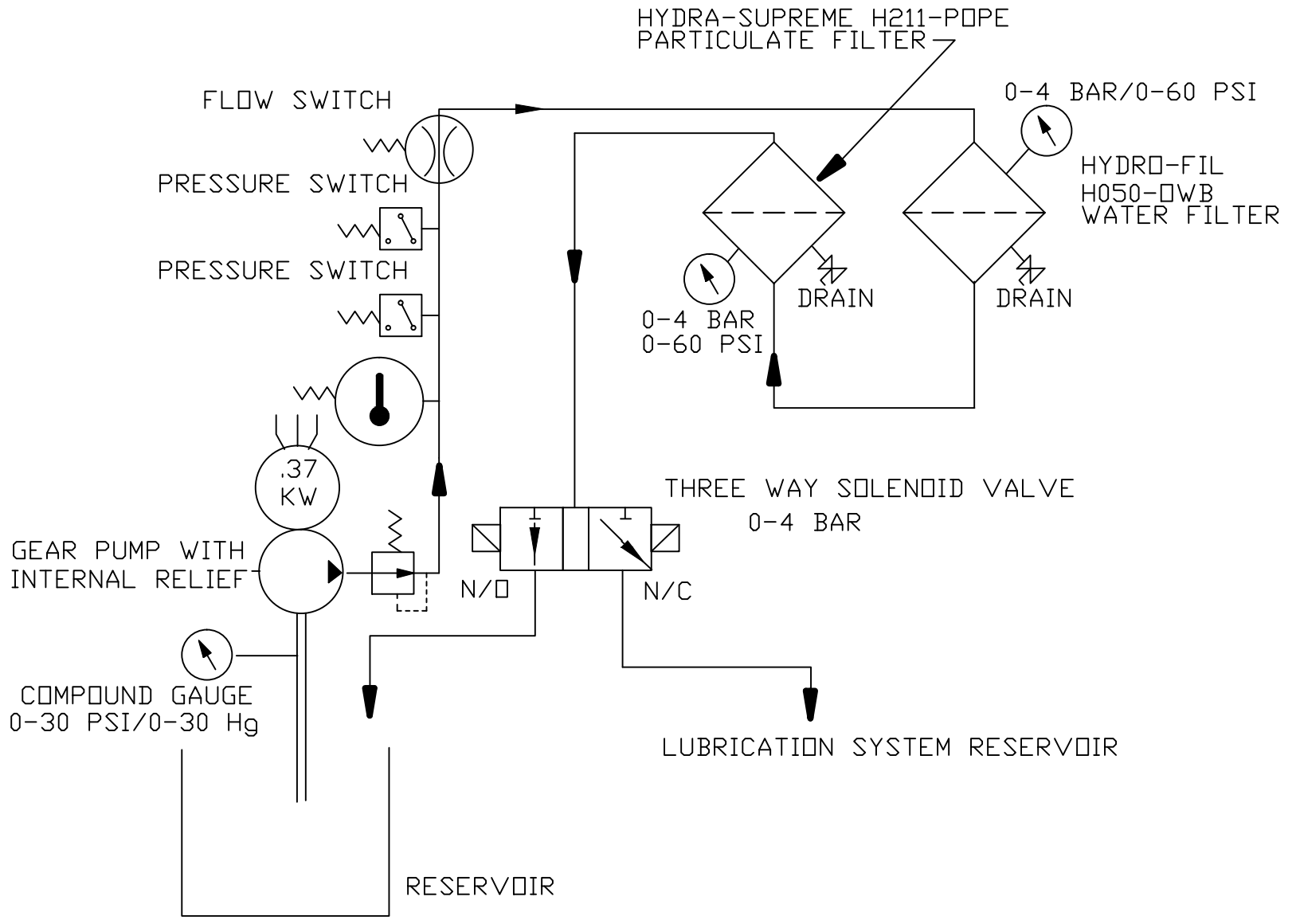

DWG. TITLE <b>PSA FLOW SCHEMATIC</b>				<b>HTI FILTRATION INC.</b>		<b>FILTRATION FLOW SCHEMATIC</b>				
PROJECT DESCRIPTION <b>SEAMER PARTICULATE AND WATER REMOVAL SYSTEM</b>						7716 GARY WATSON PT COLORADO SPRINGS CO USA 80915		-	-	-
JOB NO.	DRAWING NO.	REVISION	CUST. CONTR. NO.			REV.	DATE:	DRWN BY	CHKD BY	DESCRIPTION
-	830-002.5	0	-			CUSTOMER				PNEUMATIC SCALE - ANGELUS

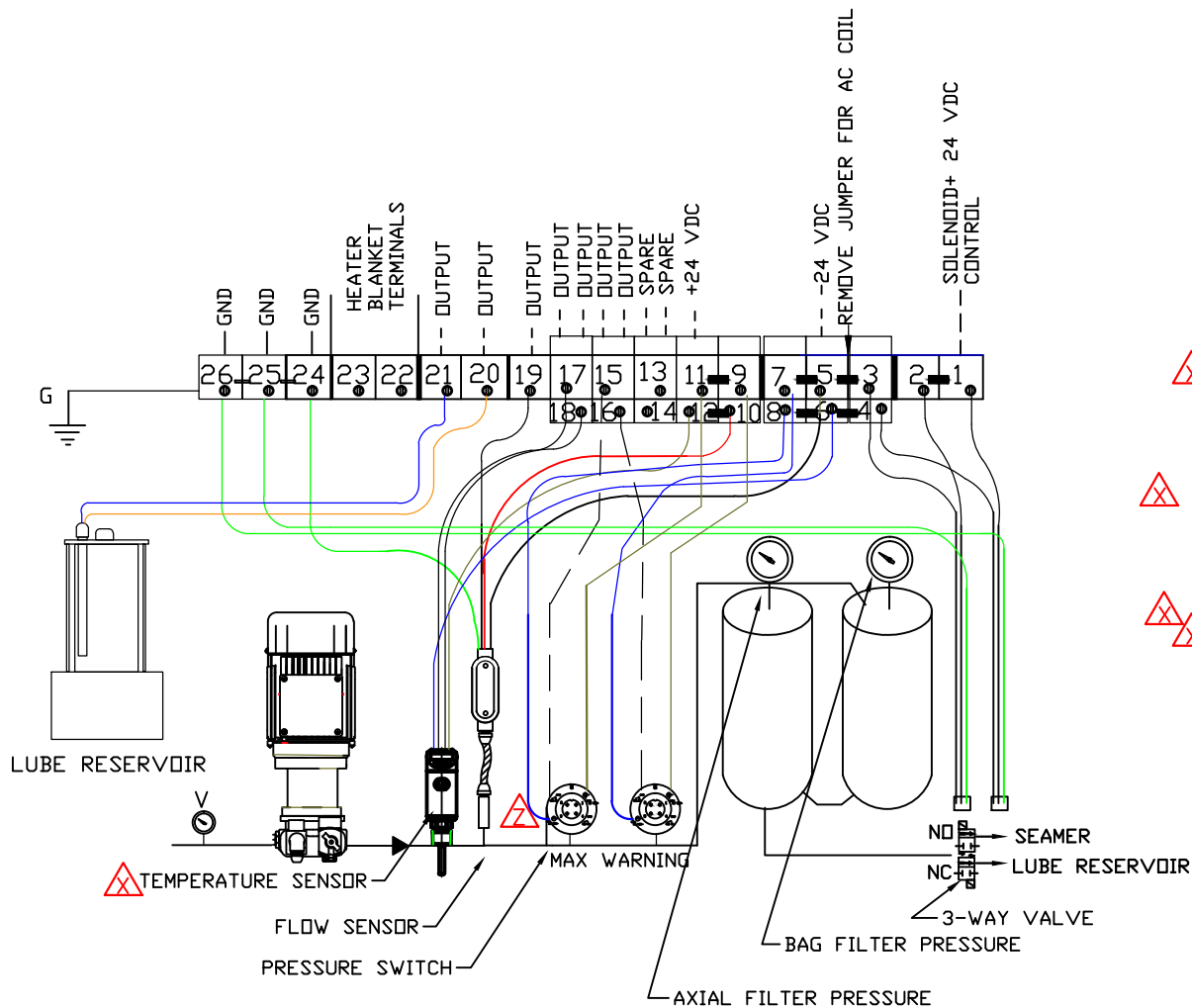

WIRE COLOR CODE

- 1. BLACK #1 Boost Solenoid N/D +24VDC
- 2. BLACK #1 Boost Solenoid N/C +24VDC
- 3. BLACK #2 Boost Solenoid N/C -24VDC
- 4. BLACK #2 Boost Solenoid N/D -24VDC
- 5. BLACK Flow Sensor -24VDC
- 6. BLUE Temperature Sensor -24VDC
- 7. BLUE PSI Switch Warning -24VDC
- 8. BLUE PSI Switch Max -24VDC
- 9. BROWN PSI Switch +24 VDC
- 10. RED Flow Sensor +24VDC
- 11. BROWN PSI Switch +24VDC
- 12. BROWN Temperature Sensor +24VDC
- 13. SPARE
- 14. SPARE
- 15. WHITE PSI Switch Max Output
- 16. WHITE PSI Switch Warning Output
- 17. WHITE Temperature Sensor Output , Out2
- 18. BLACK Temperature Sensor Output. OUT1
- 19. WHITE Flow sensor Output , N/D
- 20. ORANGE Trabon High Output N.C.
- 21. BLUE Trabon Low Output N.D.
- 22. SPARE Heater Band
- 23. SPARE Heater Band
- 24. GREEN/YELLOW ST Flow Sensor GND .
- 25. GREEN/YELLOW ST Boost Solenoid N/C .
- 26. GREEN/YELLOW ST Boost Solenoid N/D.

640-004 TEMPERATURE SENSOR-DIGITAL

DWG. TITLE <b>830-002.5 WIRING LAYOUT</b>				HTI <b>FILTRATION INC.</b>		<b>830-002.5</b>				
PROJECT DESCRIPTION <b>F0029H614</b>				7716 GARY WATSON PT COLORADO SPRINGS COLORADO USA 80915		Y	06-25-20	SP	SP	WIRING CHANGE
						X	05-28-20	SP	SP	TEMP SENSOR CHANGE
						REV.	DATE:	DRWN BY	CHKD BY	DESCRIPTION
DATE	DRAWING NO.	REVISION	CUST. CONTR. NO.	CUSTOMER						
04-11-22	830-002.5 WS	Y	-	PNEUMATIC SCALE-ANGELUS						

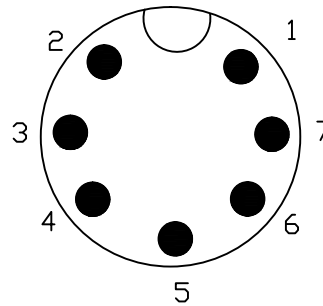
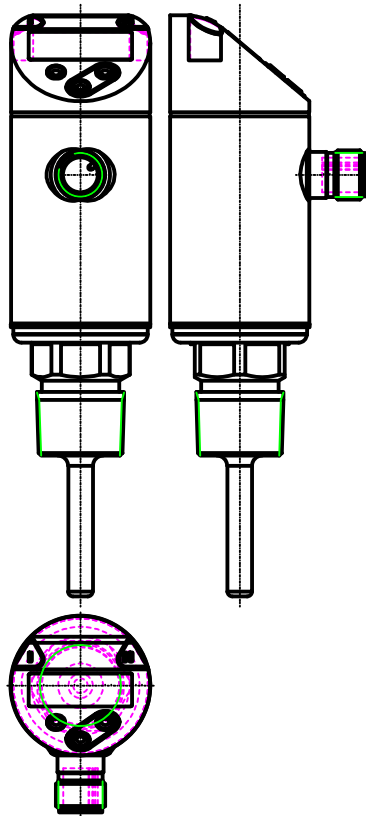

PROGRAMING OF SWITCH OUTPUTS:

Hno = HYSTERESIS IS / NO

Hnc = HYSTERESIS IS/ NC

Fno = WINDOW / NO

Fnc = WINDOW / NC

ELECTRICAL DATA-

DESIGN - DC PNP

OPERATING VOLTAGE - 18..30 VDC

CURRENT CONSUMPTION  $I_{max}$  <80

PROTECTION CLASS III

REVERSE POLARITY PROTECTION - YES

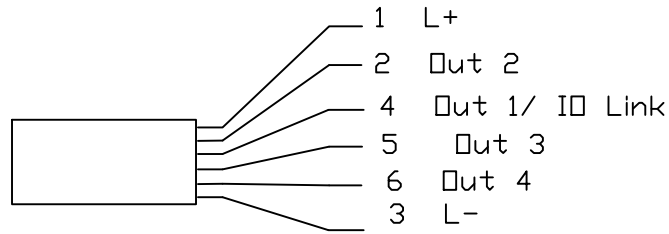

DWG. TITLE TEMPERATURE SENSOR ILLUSTRATION				HTI FILTRATION						
PROJECT DESCRIPTION TEMPERATURE SENSOR 640-004				7716 GARY WATSON PT COLORADO SPRINGS CO USA B0915		0	03-10-21	SP	SP	ORIGINAL ISSUE
JOB NO.	DRAWING NO.	REVISION	CUST. CONTR. NO.	REV.	DATE:	DRWN BY	CHKD BY	DESCRIPTION		
-	640-004		-					CUSTOMER		

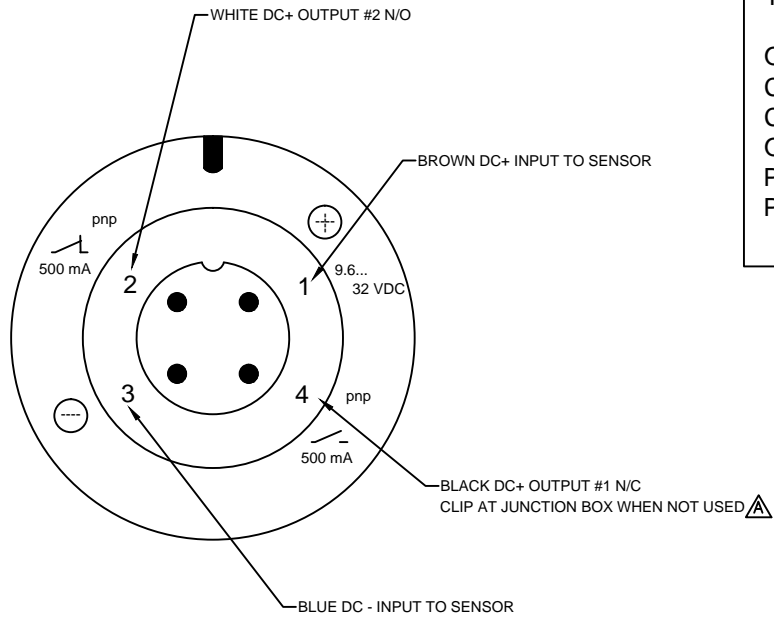

TECHNICAL DATA -	
OPERATING VOLTAGE -	9.6 TO 32 VDC
CURRENT RATING (mA) -	500
CURRENT CONSUMPTION -	<25
OPERATING TEMPERATURE -	-25 TO 80 C
PROTECTION -	IP 67 / III
PRESSURE RANGE-	0...10 BAR 0...145 PSI

NOTE:  
 USE 620-005 RIGHT ANGLE CONNECTOR  
 M12 micro DC (4 pin) 5m 22 AWG, Black  
 PUR jacket

USE 620-006 CLEAR COVER

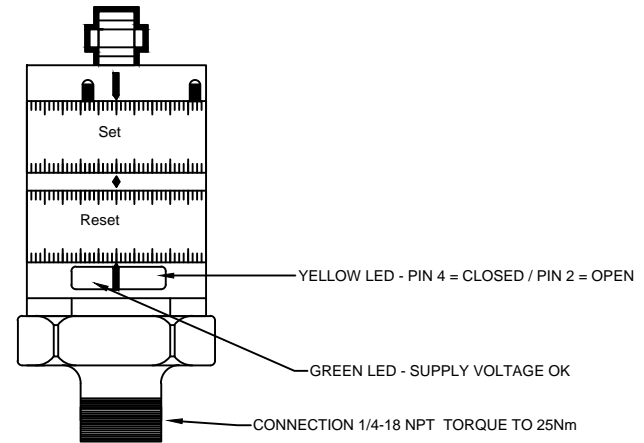

DWG. TITLE PRESSURE SWITCH ILLUSTRATION				HTI FILTRATION						
PROJECT DESCRIPTION PRESSURE SWITCH 620-004						7716 GARY WATSON PT COLORADO SPRINGS CO 80915				
JOB NO.	DRAWING NO.	REVISION	CUST. CONTR. NO.	A	—	A	02-20-24	SP	SP	ADD NOTATION
—	620-004	A	—	—	—	0	08-10-12	SP	SP	ORIGINAL ISSUE
				REV.	DATE:	DRWN BY	CHKD BY	DESCRIPTION		
				CUSTOMER						

**TROUBLESHOOTING GUIDE**  
**ANGELUS SANITARY CAN SEAMER FILTRATION SYSTEM**  
**HYDRA-SUPREME MODEL H-211-ASC R3-R6**

When using this guide please remember that all pressure and flow readings are to be taken with the system at normal operating temperatures.

SYMPTOM	CAUSE	CORRECTIVE ACTION
ERRATIC FLOW RATE, BUBBLES IN OIL STREAM	AIR LEAK IN FITTINGS, BLEED COCK OR VACUUM GAUGE	CONFIRM THAT VACUUM BLEED AND GAUGE ARE AIR TIGHT, CHECK FITTINGS
	AIR LEAK UNDER RELIEF PUMP ADJUSTMENT NUT	MAKE SURE TORQUE STRIPE ON ACORN NUT IS INTACT, REPLACE SEAL IF BROKEN
	LOOSE OR PINCHED FEED TUBE CONNECTION	MAKE SURE ALL PLUMBING CONNECTIONS ARE TIGHT
	LOW FLUID LEVEL	CHECK FLUID LEVEL IN RESERVOIR
EXCESSIVE VACUUM (ABOVE 15")	FLOW RESTRICTION	CHECK INLET PIPING FOR RESTRICTION, BLOCKAGE
	INLET PIPING RESTRICTION	CONFIRM ¾"-1" INLET PIPING SIZE
	OIL TOO THICK (OVER 900 SUS @100°F)	CHANGE TO LIGHTER GRADE OF OIL
	ENVIRONMENT TOO COLD - LESS THAN 60° FARENHEIT	INSULATE FEED LINE TO FILTER, HEAT CANISTERS
	SEAMER RUNS TOO COLD-OIL DOESNT' GET OVER 80° F.	CHANGE TO LIGHTER GRADE OIL
	AMBIENT AIR AND SEAMER TEMPERATURE UNDER 80° F.	INSTALL HEAT BLANKET ON FILTER CANISTER
LOW FLOW RATE WITH LOW PRESSURE	AIR BUBBLE IN PUMP	OPEN AIR VENTS TO BLEED OF AIR
	INSUFFICIENT MOTOR POWER GENERATED	CHECK FOR PROPER PUMP VOLTAGE AND ROTATION
	OIL BYPASSING THROUGH RELIEF VALVE	CHECK RELIEF VALVE FOR PROPER SETTING

SYMPTOM	CAUSE	CORRECTIVE ACTION
LOW FLOW RATE WITH HIGH PRESSURE	LOADED FILTER	REPLACE FILTER ELEMENT
	RESTRICTED OUTLET LINES	CHECK AND CLEAR RETURN LINES
EXCESSIVE PRESSURE	RELIEF VALVE SET TOO HIGH	CHANGE FILTER AND RE-SET RELIEF VALVE TO 65 PSI
PUMP WON'T WORK AFTER ELEMENT CHANGE OR STRAINER CLEANING	VACUUM LOCK IN PUMP	BLEED AIR OFF AT BLEED VALVE ON PUMP OUTLET
UPPER TURRET OR LUBRICATOR WON'T FILL	FAULTY SOLENOID COIL	CHECK COIL ON SOLENOID, REPLACE IF DEFECTIVE
CANISTERS LEAK AT LID CLAMP	CUT OR ERODED SEAL	CHECK SEALS FOR DAMAGE
	LID NOT TIGHT	TIGHTEN CLAMP BOLT

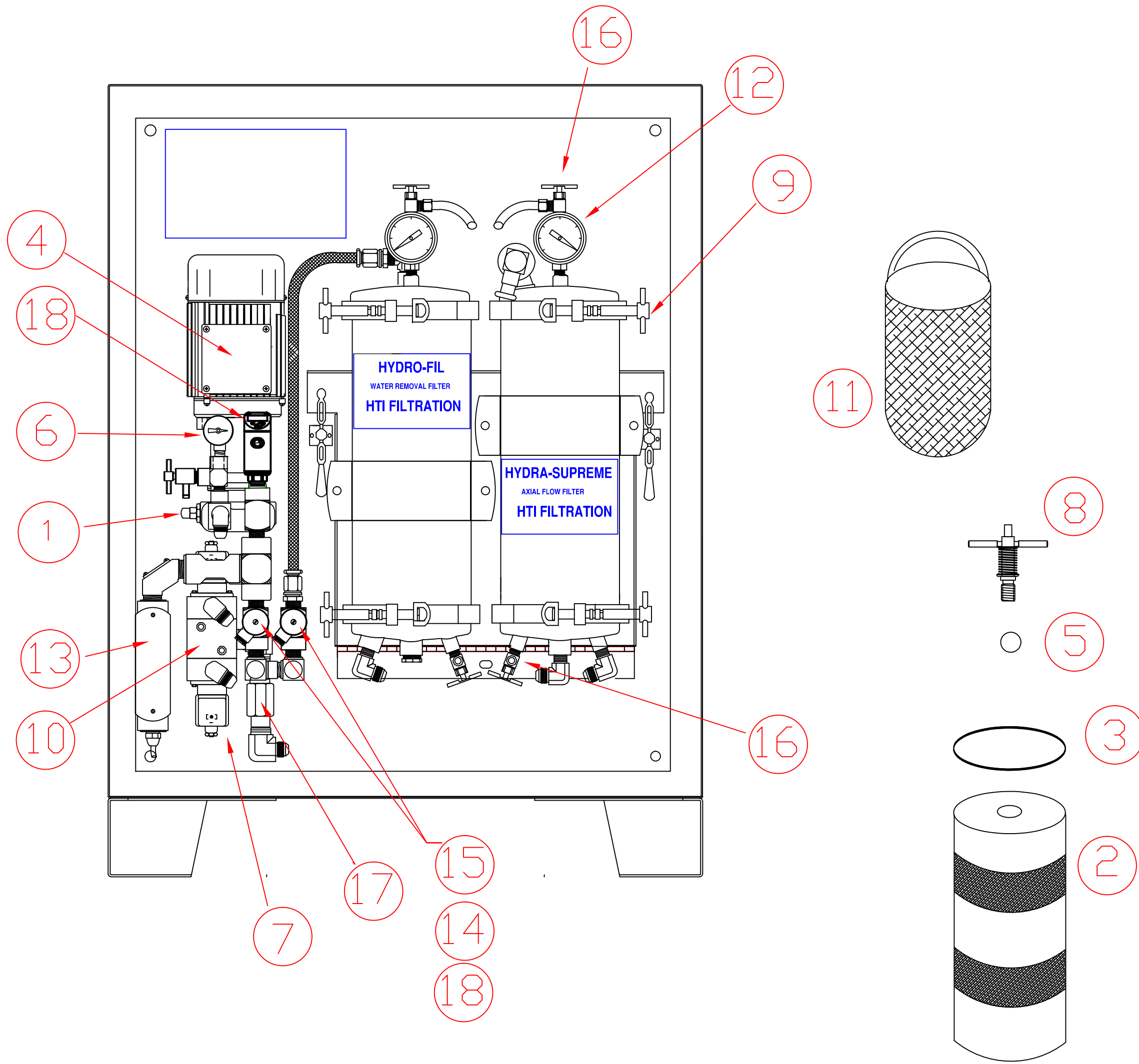

### PARTS LIST

ITEM NO.	DESCRIPTION	DWG. NO
1	PUMP	770-013
2	H211-POPE FILTER	800-016
3	CANISTER O-RING	450-001
4	MOTOR 3 PHASE 50/60 HZ .33 HP/.25 Kw 1700 RPM	780-029
5	T-HANDLE SEAL	450-003
6	COMPOUND GAUGE	610-013
7	COIL 24 VDC	430-087
8	T-HANDLE	860-001
9	CLAMP ASSEMBLY	540-005
10	VALVE ASSEMBLY	430-074
11	WATER ABSORPTION BAG	800-004
12	PRESSURE INDICATOR	610-010
13	FLOW SENSOR	620-010
14	PRESSURE SWITCH CABLE	620-005
15	PRESSURE SWITCH	620-004
16	BLEED/DRAIN VALVE	430-004
17	CHECK VALVE	430-079
18	PRESSURE SWITCH COVER	620-006
19	TEMPERATURE SENSOR	640-004

DWG. TITLE  
830-002.5 F029H614 AAAQ5

PROJECT DESCRIPTION  
SEAMER FILTRATION SYSTEM

JOB NO.	DRAWING NO.	REVISION	CUST. CONTR. NO.
—	830-002.5PL	C	—

**HTI  
INC**  
7716 GARY WATSON PT  
COLORADO SPRINGS  
COLORADO USA 80915

REV.	DATE:	DRWN BY	CHKD BY	DESCRIPTION
C	12-09-20	SP	SP	CHANGE TEMPERATURE SENSOR
B	02-11-19	SP	SP	ADD MOTOR DETAIL
A	01-01-13	SP	SP	CHANGE PRESSURE SENSOR
0	09-16-10	SP	SP	ORIGINAL ISSUE

CUSTOMER —



**HTI FILTRATION INC.**

---

**7716 Gary Watson Pt. • Colorado Springs, CO 80915 • 719.490.8800 • sales@htifiltration.com**

## **STANDARD WARRANTY**

This filter system was inspected before shipment from our plant. To the original purchaser of this system, HTI Filtration warrants its products free from defects in material and workmanship for a period of one (1) year from date of purchase.

HTI Filtration makes no other express warranty and excludes (and buyer waives) any and all implied warranties including, without limitation to, implied warranties in connection with the design, sale, merchantability or fitness of the goods for any particular use or purpose.

In order for any claim under this warranty to be valid, HTI Filtration must receive notice in writing from the buyer within a reasonable time period, not to exceed thirty (30) calendar days after any defect is discovered. The claim must include a detailed report of the conditions of use at the time of discovery of defect. Parts which fail or become defective during the warranty period (except as a result of freezing, melting, improper installation, use or care), shall be replaced or repaired at HTI Filtration's option at no charge within 90 days of the receipt of the defective part, barring unforeseen delays. HTI Filtration shall in no event be responsible for the repairs made by others without the express written permission and consent of HTI Filtration.

To obtain warranty replacement or repairs, defective components or parts should be returned, freight prepaid, to place of purchase or nearest authorized service center. HTI Filtration shall not be responsible for cartage, removal and/or reinstallation labor or any other such costs incurred in obtaining warranty replacements. In no event shall HTI Filtration be responsible for any incidental or consequential damage, whether foreseeable or not and whether or not such damage occurs, or is discovered before or after repair or replacement.

The forgoing warranty does not apply to wear components, seals or filtration elements.

This warranty extends only to the original buyer and HTI Filtration makes no other warranty, expressed or implied, to other persons or entities. If buyer makes any warranty or representation inconsistent with or in addition to the warranty stated hereinabove, the buyer shall, at their own expense, defend and hold HTI Filtration harmless from any claim thereon of any nature whatsoever.