

OPERATORS MANUAL

HYDRA-CLEAN FLUID SCRUBBING SYSTEM

HC211-ASC-R1-R6

Angelus F029H614

INTRODUCTION:

Hydra-Clean fluid scrubbing systems are high performance industrial filters designed to remove particulate and water from hydraulic and lubricating oil systems. Manufactured from durable, corrosion resistant materials, they are designed for constant, uninterrupted use without immediate supervision. The HTI 830-011.1 system utilizes two elements in series to remove water, and then particulate from the working fluid. This system ensures a high degree of fluid purity with an absolute minimum of maintenance and service requirements.

This operating manual is designed to provide you with the basic information to economically and efficiently service your fluid scrubbing system. HTI welcomes your comments and our technical service staff is available to assist you in applying our equipment to solve your fluid purity problems.

SYSTEM OPERATION:

The 830-011.1 filtration system uses two separate filtration elements in series to progressively clean the working fluid. Fluid pressure is provided by the reservoir mounted pump. The fluid is pushed through the flow sensing and pressure switch assembly into the first canister of the filtration system where the water removal bag where moisture is absorbed. The partially cleaned solution then passes through the axial flow; media filter where both soft and hard particulate contamination is removed. The filtered oil then passes through a solenoid operated selector valve and back into the seamer or the pressurized lubrication system reservoir. If the contamination level in the oil is high, or if the filters are nearing capacity, several passes through the system may be required for total cleansing of the oil.

The check valve mounted on the pump assembly ensures adequate oil supply to wet the pump during start-up and prevents drain back when the system is shut-off. The vacuum gauge indicates the resistance to flow and has a manual bleed cock that should be cracked open for safety relief during initial start-up in case the motor is rotating backwards. Typical vacuum readings are from 3 - 10 " (The bleed cock on the outlet elbow of the pump is to relieve entrapped air from the pump chamber so that oil can be drawn in to restore pump suction.

An internal relief valve that is factory set at 75-PSI controls pump output pressure. We do not recommend changing this setting. Removing the acorn nut without proper tools can result in an intake air leak that will require a new gasket to correct.

The pump output and service life of the two filter elements are monitored by a series of

flow and pressure switches. The flow switch monitors the volume of oil being pumped through the system. It is used to indicate when flow through the system has dropped below the minimum level required for adequate oil cleansing and replenishment of the seamer lubrication pump reservoir. A flow failure is indicated by the red "no oil flow" light on the main panel and the extinguishing of the indicator lamp inside the flow switch. The flow switch is factory set at .22-.25 GPM (.83 -.95 l/min) and field adjustment is not advised. A pair of stepped pressure switches monitors the system pressure. The initial switch activates the amber "Check Filter" light on the main panel. The secondary pressure switch illuminates the "Change Filter" light. Pressure switch settings are field adjustable and must be set to reflect the type of oil used and operating temperatures the filter is working with to receive maximum use from the filters. The initial (lower) switch typically activates at 5-6 PSI (.45 Bar) above the start-up pressure and the upper, Change Filter light illuminates at 10 PSI (.66 Bar) above that setting. Complete field adjustment instructions are included in this manual.

The selector valve is operated by remote sensing switches and timers, which vary depending on which options are selected at the time of order. The maximum line resistance pressure on the diverter pump should be less than 25 PSI (1.75 Bar) when the valve is activated.

SYSTEM PRESSURES:

Pressure readings will vary widely with the oil viscosity, ambient air temperature and temperature of the oil entering the filtration system. It is also not unusual for system pressures to rise substantially over normal levels when re-starting a system that has been left off for several days or when changing particulate filters. Typically the system will return to normal levels after 45-60 minutes as the warm oil from the seamer flushes out the cooler oil from the filter elements and the filtration passages in the new element open under pressure. A timed delay in the pressure switch alarms has been programmed in for these reasons. In cold climates it may be necessary to heat the Hydra-Supreme axial filter canister to maintain the desired 90-95°F operating temperature.

Factory Set Warning Pressures and Change Out Pressures

Using 750 SUS (40 Wt.) lubricant @ 75°F

Warning Switch - 65 PSI Change Filter Switch - 75 PSI

Typical bag element change out is 5-6 PSI increase over new element pressure. All measurements should be made when system is fully warmed to operating pressure.

OIL SELECTION INFORMATION:

HTI has tested many oils commonly used in seamers. While we do not recommend a specific brand or type of oil we do recommend that you use a high quality oil that has good hydrolytic stability. That is, an oil that can be exposed to water repeatedly and dried without deleting or precipitating the additive package.

The viscosity of the oil plays a major role in determining the operating pressure of the system. A 40 Wt. oil rated at 750 SUS at 100°F is actually 2,000 SUS at 75° F, a 260% increase in viscosity! Even small temperature changes can result in significant pressure variations in the system. It is not uncommon for a cold filter system to read higher pressures in the morning and then have them drop off as the system components warm over several hours to an even operating temperature.

Field Adjustment of Pressure Switches

Before changing any settings on a Hydra-Clean Fluid Conditioning System run the seamer and filter until the oil is at the normal operating temperature (typically between 95-105°F). This normally takes several hours because of the relatively low flow volume and high metal mass of the components.

NOTE: Do not attempt to reduce or increase the operating pressure by adjusting the internal pressure relief valve on the pump. This safety devise has been set and locked into place at the factory. Attempting to adjust the pressure setting screw can jam the relief valve and prevent proper movement. Improperly removing the acorn nut may also result in air leaking into the system, which will require frequent system bleeding until the acorn nut seal is replaced.

1. Turn filter system on and allow oil to fill both canisters while venting the air through the bleed cocks on the canister lids.
2. As soon as fluid flows from bleed cock, close and secure.
3. Allow filter system to run for 60-120 minutes to flush cold oil out of the filters and bring entire system up to operating temperature. Note the operating pressures of the filters.
4. Slowly close the 1/4" ball valve at the base of the Hydra-Supreme (left hand

side) canister until the system pressure is 5-6 PSI higher than the reading in Step 3.

5. Remove cover of warning pressure switch (lower switch) and adjust it by rotating the SET ring until LED illuminates. The RESET ring should be set 5 PSI below the level of the SET ring. Place the cover back on the switch
6. Increase system pressure by 2-4 PSI by further closing the valve and then adjust the maximum pressure switch (left-hand switch) the same way as in Step 5.
7. Open the ball valve to relieve the pressure build-up and allow the system to run for 10-15 minutes before recording the pressures for future reference.

Field Adjustment of Pressure Switches

Before changing any settings on a Hydra-Clean Fluid Conditioning System run the seamer and filter until the oil is at the normal operating temperature (typically between 75-100°F). This normally takes several hours because of the relatively low flow volume and high metal mass of the components.

NOTE: Do not attempt to reduce or increase the operating pressure by adjusting the internal pressure relief valve on the pump. This safety device has been set and locked into place at the factory. Attempting to adjust the pressure setting screw can jam the relief valve and prevent proper movement. Improperly removing the acorn nut may also result in air leaking into the system, which will require frequent system bleeding until the acorn nut seal is replaced.

To adjust the pressure switches use a multi-meter with the leads connected to terminals 1 - Power (bottom spade fitting) and 2 - N/C (left-hand spade fitting) or 4 - N/O (right-hand spade fitting) for indication when the contacts break. The top terminal is the ground for the switch circuit.

SYSTEM LOCATION:

Although the Hydra-Clean system uses a self-priming pump it is advisable to keep the filter below, and as close to the reservoir as possible. A suction line vacuum condition no greater than 20"hg should be experienced during start-up or normal operation. Pump damage will occur at vacuum levels above 24" hg.

Where the filter is remotely mounted from the seamer it may require a booster pump at the seamer reservoir to deliver the oil to the filter pump. The booster pump should deliver a maximum of 15-PSI pressure. Remote mounted filters will also experience higher-pressure readings due to the increased return line resistance.

Set the filtration system cabinet on a solid, level surface. Allow a minimum of 24" of frontal clearance for service access. Locate filter away from sources of moisture and heat, filter system must be kept below 140°F, and be protected from moisture.

PLUMBING:

Inlet tubing should be 3/4" with a preferred maximum distance of 20'. Smaller tubing can be utilized where the connection runs are shorter and/or the operating temperature is above 80° F.

The two return ports utilize 1/2" JIC fittings; flow selection is determined by remote activation of the solenoid valve from the main control panel. Outlet lines to the main reservoir and lubricating system should be 3/4" with a preferred maximum length of 15'-0". Ball valves can be installed at both reservoir connections for easy shut off during installation or service.

ELECTRICAL:

The motor utilizes 3 phase, 50/60 Hz power with a number of voltage options. Please check the nameplate on your motor if you are unsure of your power type.

The solenoid coil, pressure switches and flow sensor come standard using 24 VDC operating power. 110-volt power is optional for the solenoid.

The power source for the filter should be independent of the basic machine control, as the oil filtration system should run continuously for efficient contaminant control.

INITIAL START-UP PROCEDURE

Upon completion of the electrical and hydraulic connections the Hydra-Clean system is ready for start-up. The 830-011.1 is factory adjusted to perform with a fluid viscosity of 750 SUS (164 C ST at 40°C) at 75°F. To use different viscosity fluids or to run at different temperatures please make the recommended changes to the switch settings. See the previous section in this manual for further information on adjusting the pressure settings.

FILTER SYSTEM START-UP:

Turn the electrical power on to start the gear pump. Make sure the inlet and return lines to the reservoir are free of restriction and all valves are open. Crack open the bleed cocks at the top of both canisters. As soon as fluid starts to flow from the bleed hole close the cock securely and wipe the fluid from the canister top. Let the system warm up to typical operating temperature.

When initially starting the Hydra-Clean system air may enter the plumbing lines in sufficient quantity to keep the pump from priming itself or create a false reading in the oil flow sensor. Should this occur you must bleed off this trapped air by opening the bleed cock located at the pump outlet elbow just above the union.

NOTE: Your Hydra-Clean fluid scrubbing system should have no occasion to exceed 95 PSI when properly installed and using the recommended type fluid. Should a pressure condition exceed the recommended maximum immediately shut off the filtering system and contact Hydra-Tech for assistance.

FILTER ELEMENT REPLACEMENT

BAG ELEMENT:

A new bag element should be installed after the system has been in service for 6 months or shows a 5-6 PSI pressure increases.

Step 1: Turn off the Filter System. It is not necessary to turn off the seamer to service the filter.

Step 2: Open the drain cock at the bottom of the bag (right hand) canister then open the bleed cock at the top. The 3/8" hose can be used to direct the oil to a container where it can be poured back into the canister for re-use.

Step 3: Remove the canister clamp ring and lift off the lid.

Step 4: Examine the "O" ring for wear, replace this ring if it shows signs of wear or if the canister was leaking. A spare "O" ring is shipped with every system.

Step 5: Slowly lift the bag out by the strap allowing the captured oil to drain back into the canister. Hang the bag over a receptacle if you want to reclaim the approximately 3 cups of oil entrained in the bag.

Step 6: Slice open the plastic bag holding the new bag. Carefully remove the bag

and straighten to its full length. Slide the new bag into the colander using the fabric strap to push the metal bag ring down firmly onto the seat. Do not use the fabric strips inside the bag to seat the filter, they will tear off.

- Step 7: Close the drain cock and fill the bag with the drained oil captured in Step 2.
- Step 8: Put the "O" ring back on the canister lip, replace the lid, clamp and tighten.
- Step 9: Start the motor and allow the air to escape through the bleed cock. Close the cock when fluid starts to come out, wipe off the unit and check for leaks.
- Step 10: Write the date and pressure on the new service tag and attach it to the front of the canister.

AXIAL ELEMENT:

- Step 1: Turn off the Filter System. It is not necessary to turn off the seamer to service the Hydra-Supreme filter.
- Step 2: Open the drain cock on the bottom of the lid, then open the bleed cock on the top of the canister. The 3/8" ID hose can be used to direct the draining oil to a receptacle. Drained oil can later be used to refill the canister.
- Step 3: Remove the canister clamp ring and lift off the canister lid.
- Step 4: Examine the canister "O" ring for cracks and wear spots. If the canister lid seal was leaking, or if the "O" ring shows signs of wear, replace the ring.
- Step 5: Unscrew the "T" handle assembly that holds the filter in place. The cup seal on the handle assembly should be smooth and free of rough spots or tears. Replacement seals are available.
- Step 6: Slice open the end of the plastic bag holding the new element. Remove the new element and set in a clean area. Lift used element off of center post and slide it into plastic bag.
- Step 7: Slide new element over the center post. Make sure the pull strap is at the top. Secure the element with the "T" handle.
- Step 8: Close drain cock and refill canister with oil.
- Step 9: Put the "O" ring back on the canister lip, replace lid, clamp and tighten.

- Step 10: Start the pump motor and allow air to bleed out through bleed cock on top of canister. Close bleed cock when fluid starts to come out. Wipe off unit and check for leaks.
- Step 11: Write the date and operating pressure on the new service tag enclosed in plastic bag with element. Pressure should be recorded after filter has been operating for 15 minutes and machine fluid is at normal operating temperature. Attach service tag to the front of the canister for future reference.

CAUTION

Some hydrocarbon oils are not suitable for extended use after they have been mixed with water. These non-hydrolytically stable lubricants tend to precipitate out their additives, which are captured by the Hydra-Supreme axial filter element. These oils look acceptable but no longer have the original anti-wear and anti-oxidization characteristics of new oil.

HTI recommends that you use a premium grade lubricant whenever you have an on-going water contamination problem and that you consult your lubricant supplier for specific information on your specified oil.

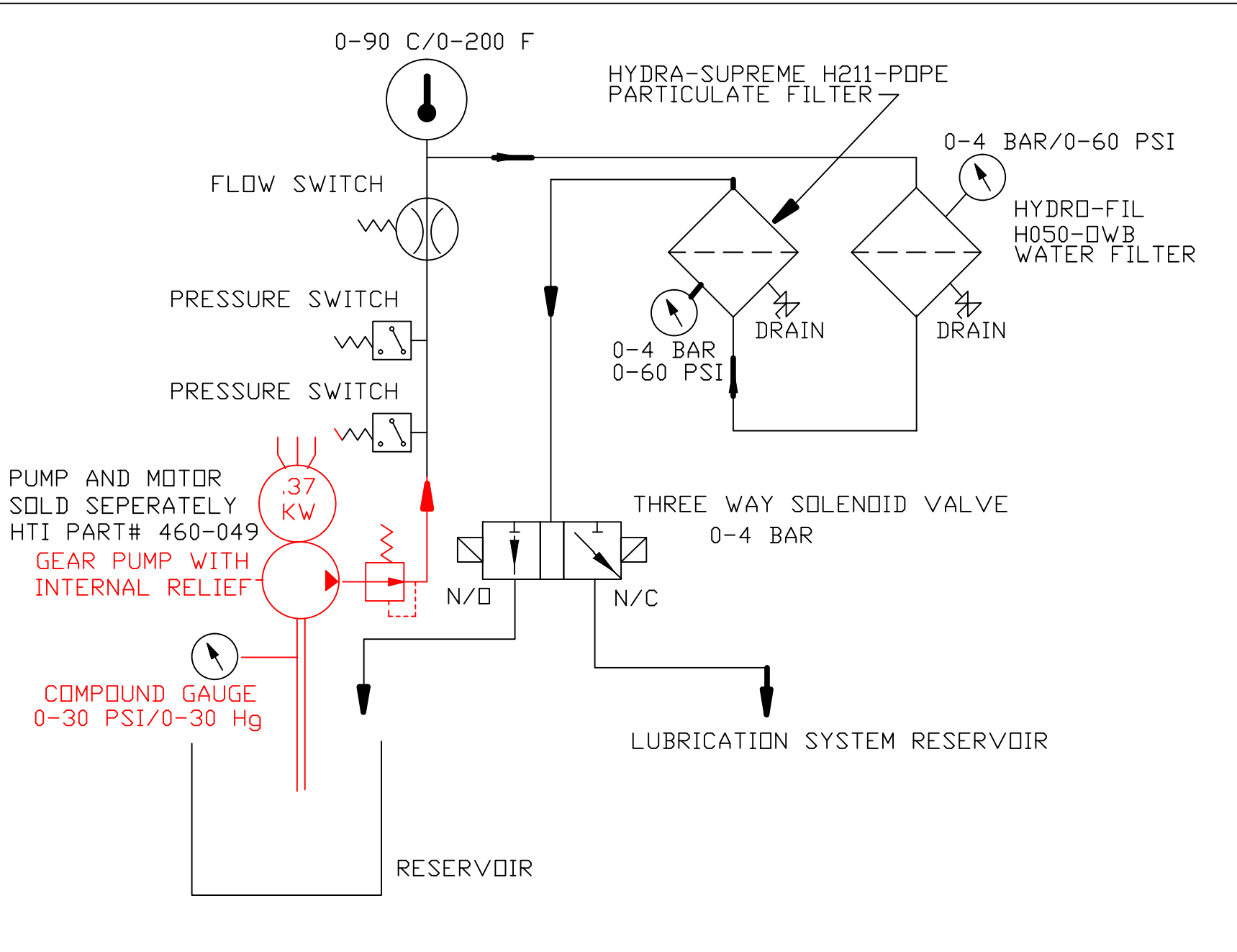

DWG. TITLE				HTI		FILTRATION FLOW SCHEMATIC					
830-011.1 FLOW SCHEMATIC				FILTRATION INC.							
PROJECT DESCRIPTION				7716 Gary Watson Pt		-					
SEAMER PARTICULATE AND WATER REMOVAL SYSTEM				Colorado Springs, CO 80915		REV.	DATE:	DRWN BY	CHKD BY	DESCRIPTION	
JOB NO.	DRAWING NO.	REVISION	CUST. CONTR. NO.	CUSTOMER							
-	830-011.1 FS	0	-	PNEUMATIC SCALE - ANGELUS							

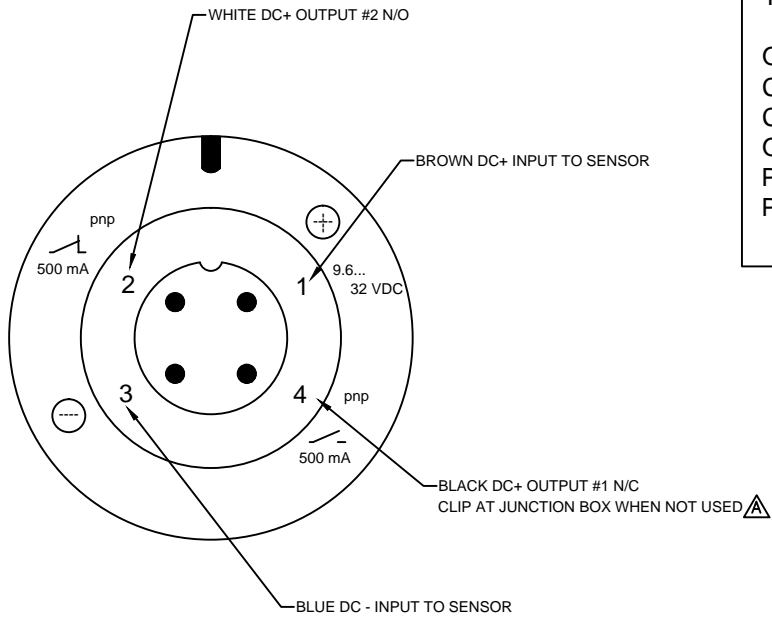

TECHNICAL DATA -	
OPERATING VOLTAGE -	9.6 TO 32 VDC
CURRENT RATING (mA) -	500
CURRENT CONSUMPTION -	<25
OPERATING TEMPERATURE -	-25 TO 80 C
PROTECTION -	IP 67 / III
PRESSURE RANGE-	0...10 BAR 0...145 PSI

NOTE:
 USE 620-005 RIGHT ANGLE CONNECTOR
 M12 micro DC (4 pin) 5m 22 AWG, Black
 PUR jacket

USE 620-006 CLEAR COVER

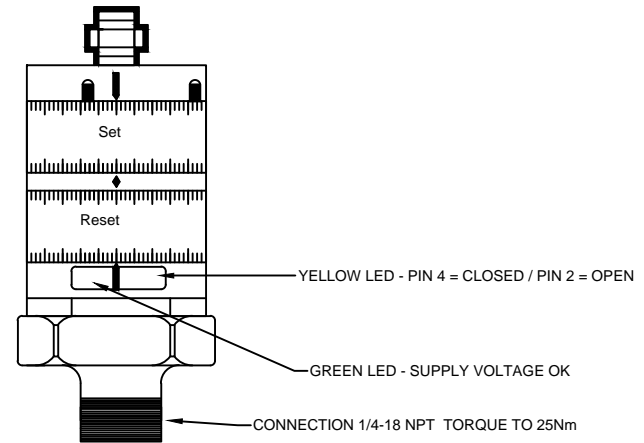

DWG. TITLE PRESSURE SWITCH ILLUSTRATION				HTI FILTRATION						
PROJECT DESCRIPTION PRESSURE SWITCH 620-004						7716 GARY WATSON PT COLORADO SPRINGS CO 80915		A	02-20-24	SP
JOB NO.	DRAWING NO.	REVISION	CUST. CONTR. NO.			0	08-10-12	SP	SP	ORIGINAL ISSUE
-	620-004	A	-			REV.	DATE:	DRWN BY	CHKD BY	DESCRIPTION
						CUSTOMER				

TROUBLESHOOTING GUIDE
ANGELUS SANITARY CAN SEAMER FILTRATION SYSTEM
HYDRA-SUPREME MODEL 830-001.3.1 R3-R-10

When using this guide please remember that all pressure and flow readings are to be taken with the system at normal operating temperatures.

SYMPTOM	CAUSE	CORRECTIVE ACTION
ERRATIC FLOW RATE, BUBBLES IN OIL STREAM	AIR LEAK IN FITTINGS, BLEED COCK OR VACUUM GAUGE	CONFIRM THAT VACUUM BLEED AND GAUGE ARE AIR TIGHT, CHECK FITTINGS
	AIR LEAK UNDER RELIEF PUMP ADJUSTMENT NUT	MAKE SURE TORQUE STRIPE ON ACORN NUT IS INTACT, REPLACE SEAL IF BROKEN
	LOOSE OR PINCHED FEED TUBE CONNECTION	MAKE SURE ALL PLUMBING CONNECTIONS ARE TIGHT
	LOW FLUID LEVEL	CHECK FLUID LEVEL IN RESERVOIR
EXCESSIVE VACUUM (ABOVE 15")	FLOW RESTRICTION	CHECK INLET PIPING FOR RESTRICTION, BLOCKAGE
	INLET PIPING RESTRICTION	CONFIRM ¾"-1" INLET PIPING SIZE
	OIL TOO THICK (OVER 900 SUS @100°F)	CHANGE TO LIGHTER GRADE OF OIL
	ENVIRONMENT TOO COLD - LESS THAN 60° FARENHEIT	INSULATE FEED LINE TO FILTER, HEAT CANISTERS
	SEAMER RUNS TOO COLD-OIL DOESNT' GET OVER 80° F.	CHANGE TO LIGHTER GRADE OIL
	AMBIENT AIR AND SEAMER TEMPERATURE UNDER 80° F.	INSTALL HEAT BLANKET ON FILTER CANISTER
LOW FLOW RATE WITH LOW PRESSURE	AIR BUBBLE IN PUMP	OPEN AIR VENTS TO BLEED OF AIR
	INSUFFICIENT MOTOR POWER GENERATED	CHECK FOR PROPER PUMP VOLTAGE AND ROTATION
	OIL BYPASSING THROUGH RELIEF VALVE	CHECK RELIEF VALVE FOR PROPER SETTING

SYMPTOM	CAUSE	CORRECTIVE ACTION
LOW FLOW RATE WITH HIGH PRESSURE	LOADED FILTER	REPLACE FILTER ELEMENT
	RESTRICTED OUTLET LINES	CHECK AND CLEAR RETURN LINES
EXCESSIVE PRESSURE	RELIEF VALVE SET TOO HIGH	CHANGE FILTER AND RE-SET RELIEF VALVE TO 65 PSI
PUMP WON'T WORK AFTER ELEMENT CHANGE OR STRAINER CLEANING	VACUUM LOCK IN PUMP	BLEED AIR OFF AT BLEED VALVE ON PUMP OUTLET
UPPER TURRET OR LUBRICATOR WON'T FILL	FAULTY SOLENOID COIL	CHECK COIL ON SOLENOID, REPLACE IF DEFECTIVE
CANISTERS LEAK AT LID CLAMP	CUT OR ERODED SEAL	CHECK SEALS FOR DAMAGE
	LID NOT TIGHT	TIGHTEN CLAMP BOLT

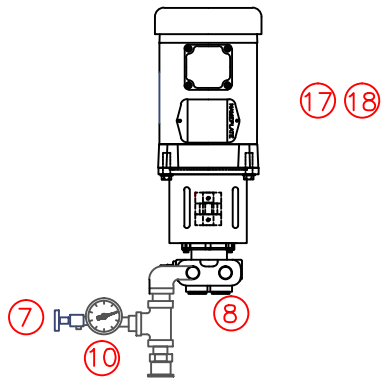

MOTOR & PUMP
SOLD SEPARATELY

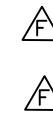
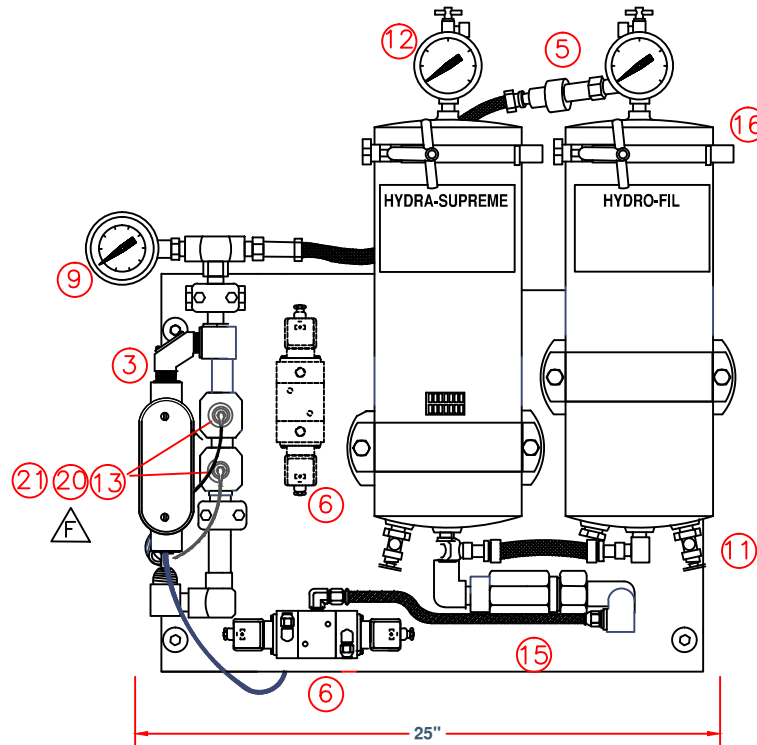
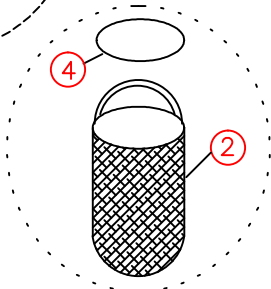
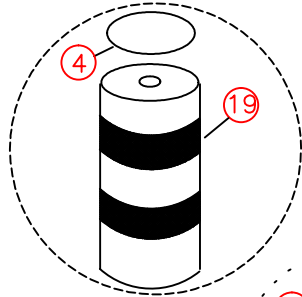

BILL OF MATERIAL

ITEM NO.	DESCRIPTION	DWG. NO
1		
2	H050-OWB	800-004
3	FLOW SENSOR	620-010
4	O-RING	270-004
5	QDC - M,F	430-001,002
6	SOLENOID VALVE	430-074
7	BLEED COCK	430-004
8	PUMP	770-013
9	TEMPERATURE GAUGE	640-001
10	COMPOUND GAUGE	610-013
11	DRAIN COCK	430-004
12	PRESSURE GAUGE	610-010
13	PRESSURE SWITCH	620-004
14	PRESSURE GAUGE	610-009
15	CHECK VALVE	430-079
16	LID CLAMP	540-005
17	MOTOR 3 PHASE 50- 60 HZ	780-015
18	MOTOR 3 PHASE 575 V	780-003
19	POPE FILTER	800-016
20	PRESSURE SWITCH CABLE	620-005
21	PRESSURE SWITCH COVER	620-006

DWG. TITLE ASCR5 FILTRATION SYSTEM AND PUMP			
PROJECT DESCRIPTION ANGELUS F029H614 ABH4			
JOB NO. -	DRAWING NO. 830-011.1F PL	REVISION F	CUST. CONTR. NO. -

**HTI
FILTRATION**
7716 Gary Watson Pt
Colorado Springs, CO
80915 USA

830-011.1 PARTS LIST				
F	01-01-13	SP	SP	CHANGE PRESSURE SWITCH
E	08/20/08	SP	SP	ADD CHECK VALVE
D	09/02/04	SP	SP	SHOW PUMP FITTINGS
REV.	DATE:	DRWN BY	CHKD BY	DESCRIPTION
CUSTOMER PNEUMATIC SCALE ANGELUS				



HTI FILTRATION INC.

7716 Gary Watson Pt. • Colorado Springs, CO 80915 • 719.490.8800 • sales@htifiltration.com

STANDARD WARRANTY

This filter system was inspected before shipment from our plant. To the original purchaser of this system, HTI Filtration warrants its products free from defects in material and workmanship for a period of one (1) year from date of purchase.

HTI Filtration makes no other express warranty and excludes (and buyer waives) any and all implied warranties including, without limitation to, implied warranties in connection with the design, sale, merchantability or fitness of the goods for any particular use or purpose.

In order for any claim under this warranty to be valid, HTI Filtration must receive notice in writing from the buyer within a reasonable time period, not to exceed thirty (30) calendar days after any defect is discovered. The claim must include a detailed report of the conditions of use at the time of discovery of defect. Parts which fail or become defective during the warranty period (except as a result of freezing, melting, improper installation, use or care), shall be replaced or repaired at HTI Filtration's option at no charge within 90 days of the receipt of the defective part, barring unforeseen delays. HTI Filtration shall in no event be responsible for the repairs made by others without the express written permission and consent of HTI Filtration.

To obtain warranty replacement or repairs, defective components or parts should be returned, freight prepaid, to place of purchase or nearest authorized service center. HTI Filtration shall not be responsible for cartage, removal and/or reinstallation labor or any other such costs incurred in obtaining warranty replacements. In no event shall HTI Filtration be responsible for any incidental or consequential damage, whether foreseeable or not and whether or not such damage occurs, or is discovered before or after repair or replacement.

The forgoing warranty does not apply to wear components, seals or filtration elements.

This warranty extends only to the original buyer and HTI Filtration makes no other warranty, expressed or implied, to other persons or entities. If buyer makes any warranty or representation inconsistent with or in addition to the warranty stated hereinabove, the buyer shall, at their own expense, defend and hold HTI Filtration harmless from any claim thereon of any nature whatsoever.