

OPERATORS MANUAL

HYDRA-CLEAN FLUID SCRUBBING SYSTEM 830-024.1

PS-A PART NUMBER 1401568-M

INTRODUCTION:

Hydra-Clean fluid scrubbing systems are high performance industrial filters designed to remove particulate and water from hydraulic and lubricating oil systems. Manufactured from durable, corrosion resistant materials, they are designed for constant, uninterrupted use without immediate supervision. The Hydra-Clean 830-024.1 system utilizes two elements in series to remove water, and then particulate from the working fluid. This system ensures a high degree of fluid purity with an absolute minimum of maintenance and service requirements.

This operating manual is designed to provide you with the basic information to economically and efficiently service your fluid scrubbing system. HTI Filtration welcomes your comments and our technical service staff is available to assist you in applying our equipment to solve your fluid purity problems.

SYSTEM OPERATION:

The 830-024.1 filtration system uses two separate filtration elements in series to progressively clean the working fluid. Fluid is drawn from the reservoir by a rotary ring gear pump into the water removal bag element where the free and emulsified moisture is absorbed. The partially cleaned solution passes through the axial-flow, media filter where both soft and hard particulate contamination is removed. The filtered oil then passes through a solenoid valve manifold and either back into the seamer or into the pressurized lubrication system reservoir. If the contamination level in the oil is high, or if the filters are nearing capacity, several passes through the system may be required for total cleansing of the oil.

The vacuum gauge at the pump head indicates the resistance to flow and has a manual bleed cock that should be cracked open for safety relief during initial start-up in case the motor is rotating backwards. Typical vacuum readings are from 3 - 10 ". Vacuum resistance above 20" can cause pump damage and should be avoided.

The pressure gauge shows the current resistance through the filter elements and is an indicator of pump operation.

The two pressure switches trigger a visual alarm at the operators display to show that a filter change is recommended or required.

The temperature gauge shows the current temperature of the oil at that point in the filtration process.

The differential pressure switches indicate the current resistance and viability of the filter elements. When the arrow is in the red zone it indicates that a filter change out is needed to maintain optimum function of the filter.

The solenoid valves on the manifold are operated by the machine controller to flush the upper turret or refill the lubrication pump reservoir. In their de-energized state, the oil returns to the machine reservoir.

SYSTEM PRESSURES:

Pressure readings will vary widely with the oil viscosity, ambient air temperature and temperature of the oil entering the filtration system. When setting the system at our factory, we utilize SSO-FG-150 ISO oil at 100 F which yields an operating pressure at startup of 30 PSI / 2 BAR. It is also not unusual for system pressures to rise substantially over normal levels when re-starting a system that has been left off for several days or when changing particulate filters. Typically, the system will return to normal levels after 45-60 minutes as the warm oil from the seamer flushes out the cooler oil from the filter elements and the filtration passages in the new element open under pressure. In cold climates, it may be necessary to heat the bag filter canister to maintain the desired minimum 90-105°F canister operating temperature. The system is designed to use 150 ISO/750 SUS lubricant @ 100°F

OIL SELECTION INFORMATION:

HTI Filtration has tested many oils commonly used in seamers. While we do not recommend a specific brand or type of oil, we do recommend that you use high quality oils with good hydrolytic stability. That is, an oil that can be exposed to water repeatedly and dried without deleting or precipitating the additive package.

The viscosity of the oil plays a major role in determining the operating pressure of the system. An oil rated at 750 SUS at 100°F is actually 2,000 SUS at 75° F, a 260% increase in viscosity! Even small temperature changes can result in significant pressure variations in the system. It is not uncommon for a cold filter system to read higher pressures in the morning and then drop off as the system components warm over several hours to an even operating temperature. If temperature attainment or stability is a problem, we recommend that you contact Pneumatic Scale Angelus about the heater blanket available for this product.

SYSTEM LOCATION:

Although the system uses a self-priming pump, it is advisable to keep the filter below, and as close to the reservoir as possible. A suction line vacuum condition no greater than 20"hg should be experienced during start-up or normal operation. Pump damage will occur at vacuum levels above 24" hg.

PLUMBING:

Pump inlet tubing should be 3/4" and the outlet hoses should be 1/2" diameter minimum.

ELECTRICAL:

The motor utilizes 3 phase power operating at 1125 RPM at 60 HZ and can also be run at 900 RPM when using 50 HZ power. A 575 volt, 60 Hz motor is optional. Please check the nameplate on your existing motors if you are unsure of your power type.

The solenoid coils come standard using 24 VDC operating power.

The power source for the filter should be independent of the basic machine control as the oil filtration system should run continuously for efficient contaminant control.

INITIAL START-UP PROCEDURE

Upon completion of the electrical and hydraulic connections the system is ready for start-up. The 830-024.1 system is factory adjusted to perform with a fluid viscosity of 150 SUS at 100°F. To use different viscosity fluids or to run at different temperatures please contact the Pneumatic Scale Angelus technical service department.

FILTER SYSTEM START-UP:

Crack open the bleed cock at the vacuum gauge. Make sure the inlet and return lines to the reservoir are free of restriction and all valves are open. Crack open the bleed cocks at the top of both canisters. Turn the electrical power on to start the gear pump. As soon a positive flow is established, you should close the bleed cock at the vacuum gauge. If oil is pushed from the bleed cock by the vacuum gauge, then the motor is running backwards! Stop the motor, reverse the direction, and start over. As soon as fluid starts to flow from the bleed valves on the canisters, close them securely and wipe any spilled fluid from the canister top. Let the system warm up to typical operating temperature.

When initially starting the system, air may enter the plumbing lines in sufficient quantity to keep the pump from priming itself or create a false reading in the oil flow sensor. Should this occur, you must bleed off this trapped air by loosening the pipe union joining the pump to the delivery valve train until the air is vented and oil flows steadily out.

FILTER ELEMENT REPLACEMENT

BAG ELEMENT: HTI # 800-003 / PS-Angelus # 1402067

A new bag element should be installed after the system has been in service for 6 months or if the indicating needle is in the red zone of the gauge.

- Step 1: Turn off the filter system motor. It is not necessary to turn off the seamer to service the filter.
- Step 2: Open the drain cock at the bottom of the bag (right hand) canister then open the bleed cock at the top. Direct the draining oil into a container. The oil can be poured back into the canister later for re-use.
- Step 3: Remove the canister clamp ring by turning the handle counterclockwise until the T-bar can be lifted from the saddle. The clamp can then be opened and removed, or laid down along the canister. Lift off the lid.
- Step 4: Examine the "O" ring for wear; replace this ring if it shows signs of wear or if the canister was leaking.
- Step 5: Slowly lift the bag out by the strap allowing the captured oil to drain back into the canister. Hang the bag over a receptacle if you want to reclaim the approximately 3 cups of oil entrained in the bag. Do not remove the metal strainer with the used bag; it stays in the canister.
- Step 6: Slice open the plastic bag holding the new filter bag. Carefully remove the bag and straighten to its full length. Slide the new bag into the colander using the fabric strap to push the metal bag ring down firmly onto the seat. Do not use the fabric strips inside the bag to seat the filter, as they will tear off.
- Step 7: Close the drain cock and fill the bag with the drained oil captured in Step 2.
- Step 8: Put the "O" ring back on the canister lip, replace the lid, clamp and tighten.
- Step 9: Start the motor and allow the air to escape through the bleed cock. Close the cock when fluid starts to come out, wipe off the unit and check for leaks.

AXIAL ELEMENT: HTI # 800-050 / PS-Angelus #1402066

- Step 1: Turn off the filter system. It is not necessary to turn off the seamer to service the Hydra-Supreme filter.
- Step 2: Open the drain cock on the bottom of the canister and then open the bleed cock on the top of the canister. Capture the oil as it can be used later to refill the canister.
- Step 3: Remove the canister clamp ring by turning the handle counterclockwise until the t-bar can be lifted from the saddle. The clamp can then be opened and removed, or laid down along the canister. Remove the lid.
- Step 4: Examine the canister "O" ring for cracks and wear spots. If the canister lid seal was leaking, or if the "O" ring shows signs of wear, replace the ring.
- Step 5: Unscrew the "T" handle assembly that holds the filter in place by turning the handle in a counter clockwise rotation. If the t-handle is stuck in place inside the filter end, you may need to rock it slightly as you turn it to remove it once the threaded portion is free from the steel center post threads. The cup seal on the handle assembly should be smooth and free of rough spots or tears. Replacement seals are available.
- Step 6: Slice open the end of the plastic bag holding the new element. Remove the new element and set in a clean area. Lift used element off of center post and slide it into plastic bag.
- Step 7: Slide new element over the center post. Make sure the metal bale is at the top and that the black "O" ring seal is still in place at the bottom. Secure the element with the "T" handle by inserting into the ferrule and turning it clockwise once it has made contact with the center post.
- Step 8: Close drain cock and refill canister with oil.
- Step 9: Put the "O" ring back on the canister lip, replace lid, clamp, and tighten.
- Step 10: Start the pump motor and allow air to bleed out through bleed cock on top of canister. Close bleed cock when fluid starts to come out. Wipe off unit and check for leaks.

CAUTION

Some hydrocarbon oils are not suitable for extended use after they have been mixed with water. These non-hydrolytically stable lubricants tend to precipitate out their additives, which are captured by the Hydra-Supreme axial filter element. These oils look acceptable but no longer have the original anti-wear and anti-oxidization characteristics of new oil.

HTI Filtration recommends that you use a premium grade lubricant whenever you have an on-going water contamination problem and that you consult your lubricant supplier for specific information on your specified oil.

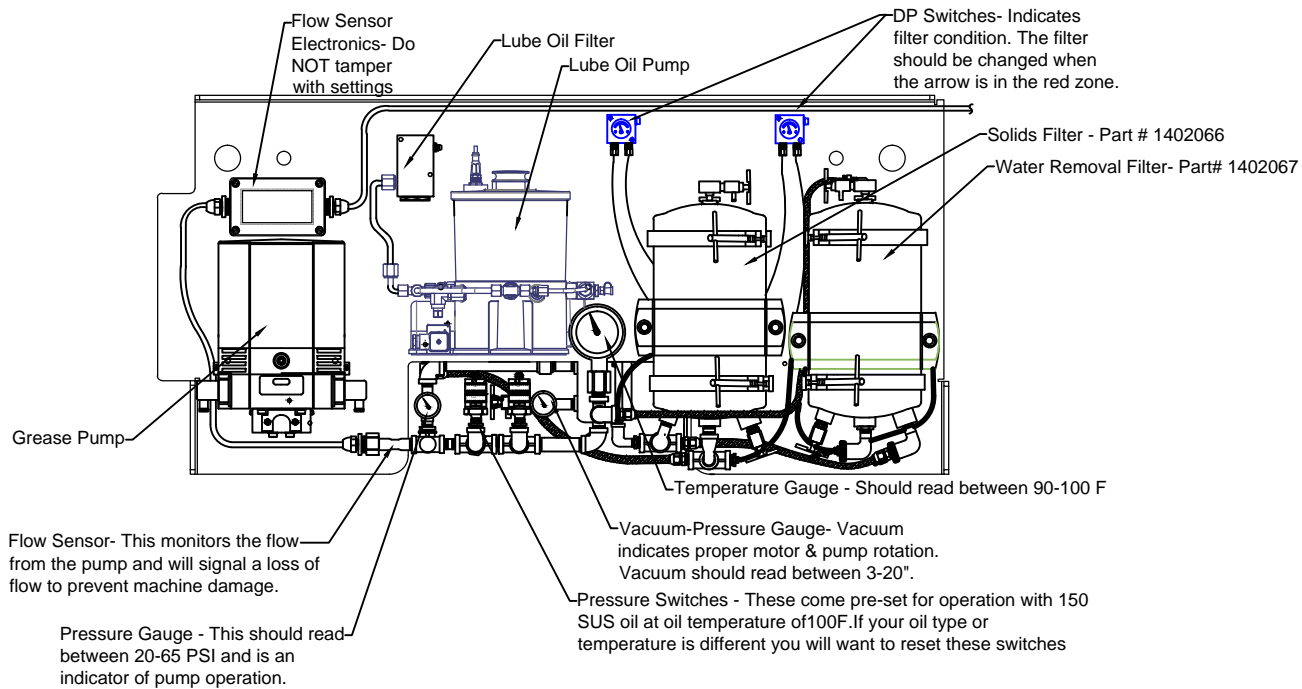
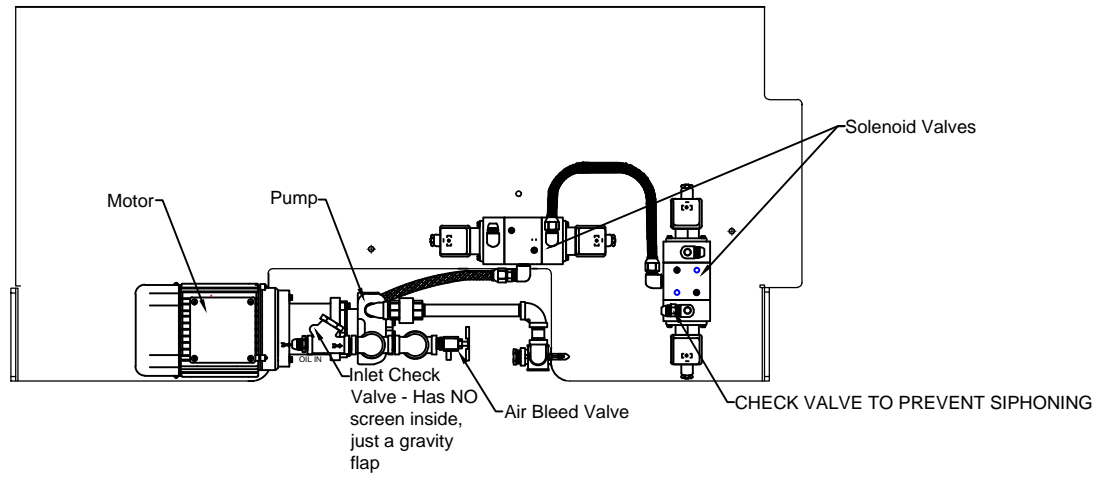

DWG. TITLE 830-024.1 FUNCTION CHART				HTI FILTRATION		830-024.1 FILTRATION SYSTEM F0190L814-AAAA LUBE ASSEMBLY				
PROJECT DESCRIPTION ANGELUS MACHINE F0190L814-AAAA LUBE ASSEMBLY				7716 Gary Watson Pt Colorado Springs, CO USA 80915		-	-	-	-	-
JOB NO.	DRAWING NO.	REVISION	CUST. CONTR. NO.	REV.	DATE	DRWN BY	CHKD BY	DESCRIPTION		
-	830-024.1 FUN	0	-	0	09-24-14	SP	SP	ORIGINAL ISSUE		
CUSTOMER						P/S -ANGELUS MACHINE				

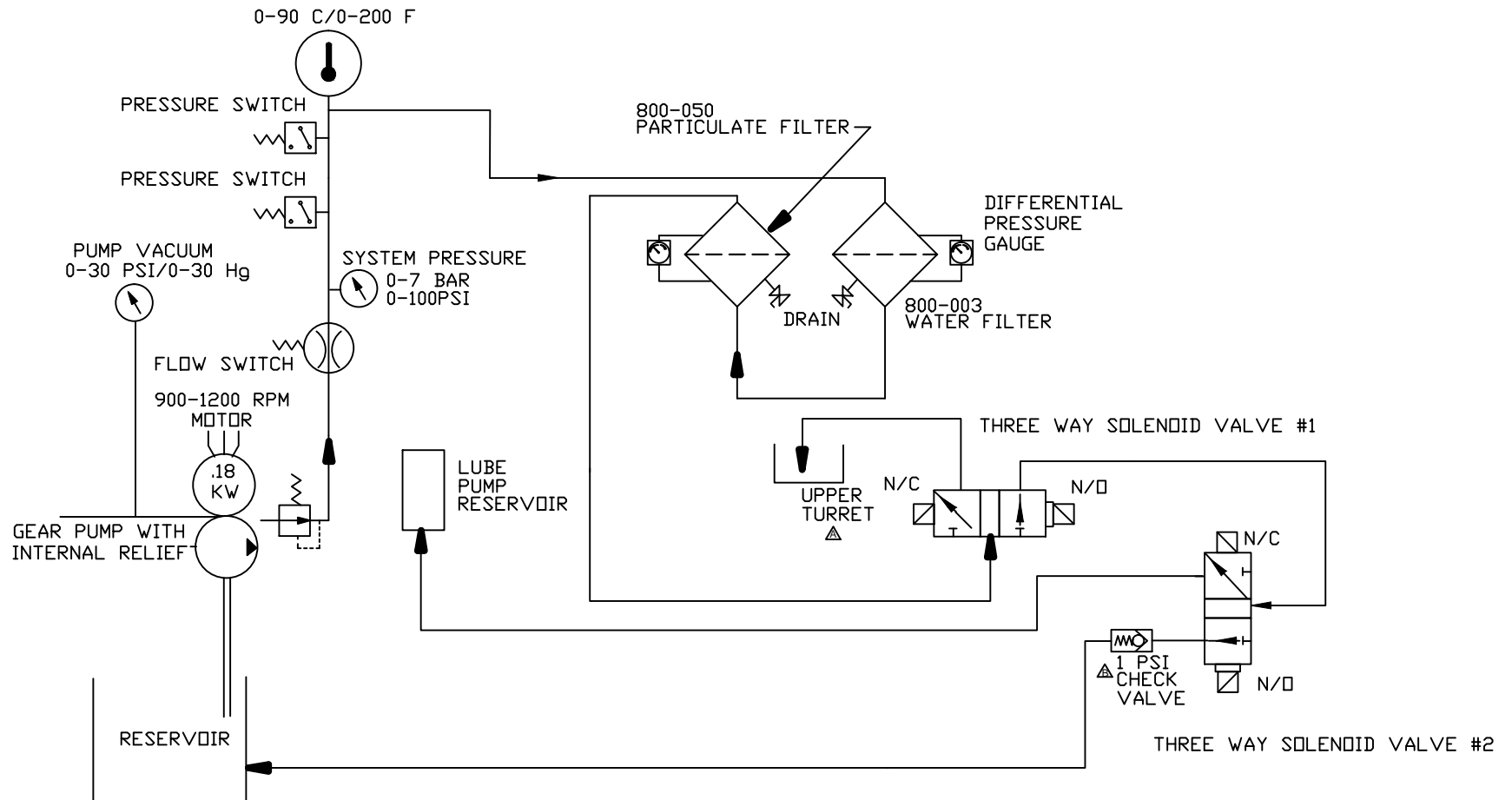

DWG. TITLE 830-024.1 FILTRATION FLOW SCHEMATIC				HTI FILTRATION INC.		PS-A F0190L814-AAAA FLOW SCHEMATIC			
PROJECT DESCRIPTION SEAMER PARTICULATE AND WATER REMOVAL SYSTEM									
7716 Gary Watson Pt Colorado Springs, CO USA 80915									
JOB NO.	DRAWING NO.	REVISION	CUST. CONTR. NO.	B	12-13-2014	SP	RH	CHANGE CV LOCATION	
-	830-024.1 FS	B	-	A	11-12-2014	SP	RH	CHANGE OIL FLOW	
				REV.	DATE:	DRWN BY	CHKD BY	DESCRIPTION	
				CUSTOMER PNEUMATIC SCALE - ANGELUS					

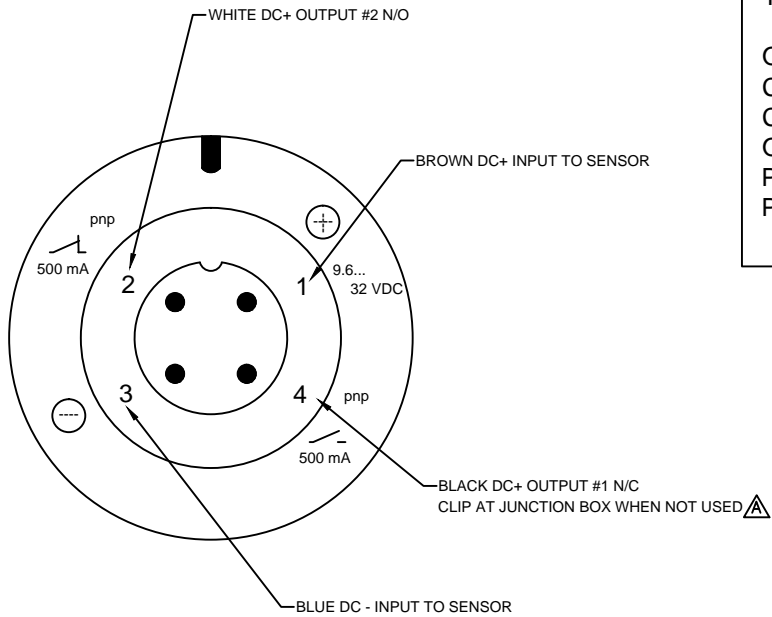

TECHNICAL DATA -	
OPERATING VOLTAGE -	9.6 TO 32 VDC
CURRENT RATING (mA) -	500
CURRENT CONSUMPTION -	<25
OPERATING TEMPERATURE -	-25 TO 80 C
PROTECTION -	IP 67 / III
PRESSURE RANGE-	0...10 BAR 0...145 PSI

NOTE:
 USE 620-005 RIGHT ANGLE CONNECTOR
 M12 micro DC (4 pin) 5m 22 AWG, Black
 PUR jacket

USE 620-006 CLEAR COVER

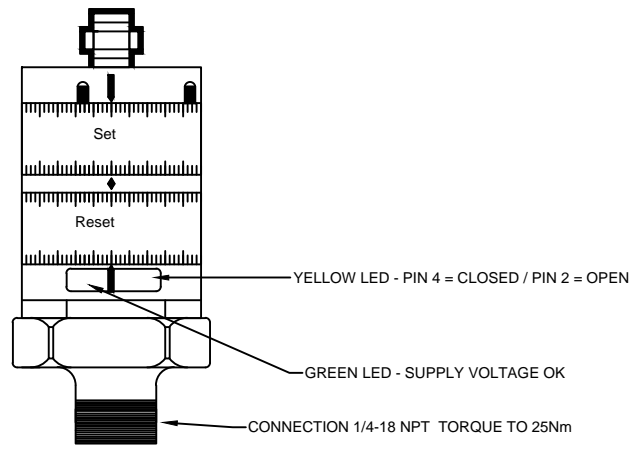

DWG. TITLE PRESSURE SWITCH ILLUSTRATION				HTI FILTRATION						
PROJECT DESCRIPTION PRESSURE SWITCH 620-004						7716 GARY WATSON PT COLORADO SPRINGS CO 80915		A	02-20-24	SP
JOB NO.	DRAWING NO.	REVISION	CUST. CONTR. NO.			0	08-10-12	SP	SP	ORIGINAL ISSUE
-	620-004	A	-			REV.	DATE:	DRWN BY	CHKD BY	DESCRIPTION
						CUSTOMER				

**TROUBLESHOOTING GUIDE
ANGELUS SANITARY CAN SEAMER FILTRATION SYSTEM
ALL HYDRA-SUPREME MODELS**

When using this guide please remember that all pressure and flow readings are to be taken with the system at normal operating temperatures.

SYMPTOM	CAUSE	CORRECTIVE ACTION
ERRATIC FLOW RATE, BUBBLES IN OIL STREAM	AIR LEAK IN FITTINGS, BLEED COCK OR VACUUM GAUGE	CONFIRM THAT VACUUM BLEED AND GAUGE ARE AIR TIGHT, CHECK FITTINGS
	AIR LEAK UNDER RELIEF PUMP ADJUSTMENT NUT	MAKE SURE TORQUE STRIPE ON ACORN NUT IS INTACT, REPLACE SEAL IF BROKEN
	LOOSE OR PINCHED FEED TUBE CONNECTION	MAKE SURE ALL PLUMBING CONNECTIONS ARE TIGHT
	LOW FLUID LEVEL	CHECK FLUID LEVEL IN RESERVOIR
EXCESSIVE VACUUM (ABOVE 15")	FLOW RESTRICTION	CHECK INLET PIPING FOR RESTRICTION, BLOCKAGE
	INLET PIPING RESTRICTION	CONFIRM ¾"-1" INLET PIPING SIZE
	OIL TOO THICK (OVER 900 SUS @100°F)	CHANGE TO LIGHTER GRADE OF OIL
	ENVIRONMENT TOO COLD - LESS THAN 60° FARENHEIT	INSULATE FEED LINE TO FILTER, HEAT CANISTERS
	SEAMER RUNS TOO COLD-OIL DOESNT' GET OVER 80° F.	CHANGE TO LIGHTER GRADE OIL
	AMBIENT AIR AND SEAMER TEMPERATURE UNDER 80° F.	INSTALL HEAT BLANKET ON FILTER CANISTER
LOW FLOW RATE WITH LOW PRESSURE	AIR BUBBLE IN PUMP	OPEN AIR VENTS TO BLEED OF AIR
	INSUFFICIENT MOTOR POWER GENERATED	CHECK FOR PROPER PUMP VOLTAGE AND ROTATION
	OIL BYPASSING THROUGH RELIEF VALVE	CHECK RELIEF VALVE FOR PROPER SETTING

SYMPTOM	CAUSE	CORRECTIVE ACTION
LOW FLOW RATE WITH HIGH PRESSURE	LOADED FILTER	REPLACE FILTER ELEMENT
	RESTRICTED OUTLET LINES	CHECK AND CLEAR RETURN LINES
EXCESSIVE PRESSURE	RELIEF VALVE SET TOO HIGH	CHANGE FILTER AND RE-SET RELIEF VALVE TO 65 PSI
PUMP WON'T WORK AFTER ELEMENT CHANGE OR STRAINER CLEANING	VACUUM LOCK IN PUMP	BLEED AIR OFF AT BLEED VALVE ON PUMP OUTLET
UPPER TURRET OR LUBRICATOR WON'T FILL	FAULTY SOLENOID COIL	CHECK COIL ON SOLENOID, REPLACE IF DEFECTIVE
CANISTERS LEAK AT LID CLAMP	CUT OR ERODED SEAL	CHECK SEALS FOR DAMAGE
	LID NOT TIGHT	TIGHTEN CLAMP BOLT

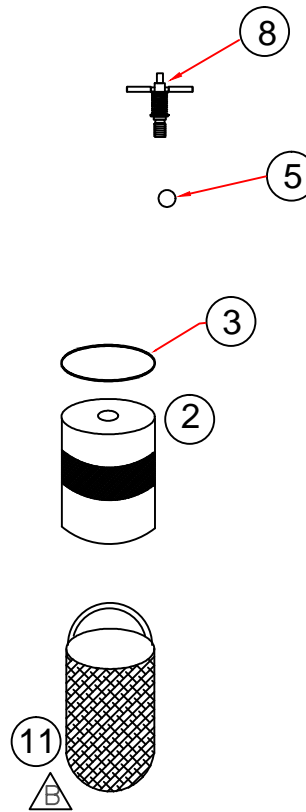
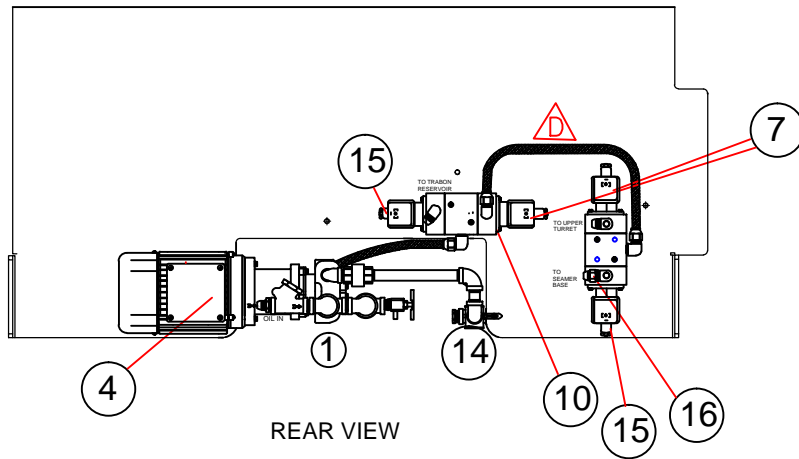
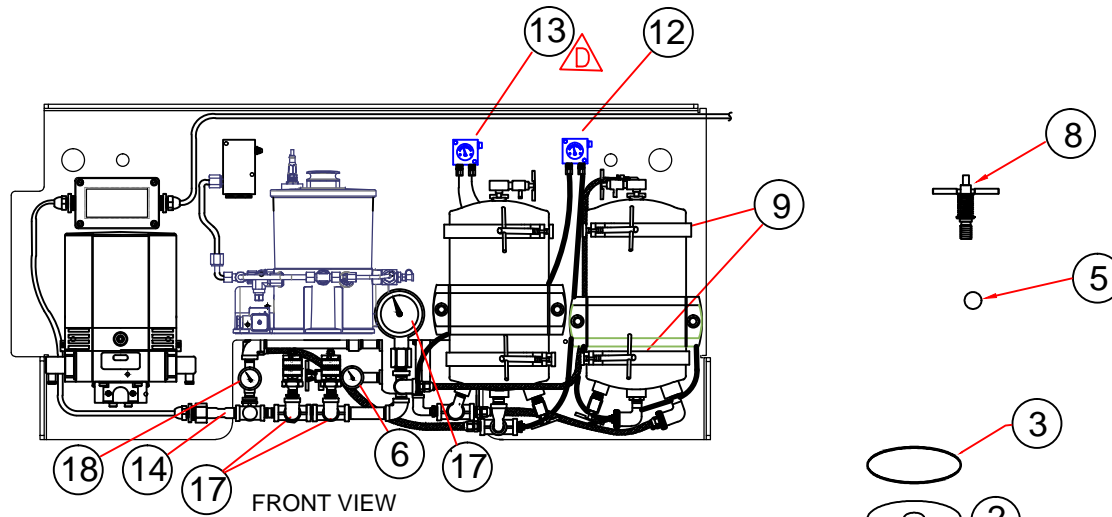

BILL OF MATERIAL

ITEM NO.	DESCRIPTION	DWG. NO
1	PUMP	770-013
2	H100-POPE FILTER	800-050
3	CANISTER O-RING	450-001
4	MOTOR 180-460 V 50/60Hz 25 HP/.18Kw.1120-900 RPM	780-031
5	T-HANDLE SEAL	450-003
6	COMPOUND GAUGE	610-013
7	COIL N/O VALVE	430-087
8	T-HANDLE	860-001
9	CLAMP ASSEMBLY	540-005
10	VALVE ASSEMBLY	430-074
11	HO25-OWB ELEMENT	800-003
12	DIFFERENTIAL PRES 0-10	610-020
13	DIFFERENTIAL PRES. 0-20	610-021
14	FLOW SENSOR	620-012
15	COIL N/C VALVE	430-087
16	BACK FLOW VALVE 1 PSI	430-089
17	PRESSURE SWITCH	620-004
18	PRESSURE GAUGE 0-100	610-007
19	TEMPERATURE GAUGE	640-001

△ A
△ C
△ B
△ D
△ B
△ B

DWG. TITLE 830-024.1 PARTS LIST				HTI FILTRATION		830-024 FILTRATION SYSTEM F0190L814-AAAA				
PROJECT DESCRIPTION ANGELUS MACHINE F0100L814-AAAA ASSEMBLY						D 12-14-22 SP SP CHANGE DP RANGE, HOSE				
JOB NO. — DRAWING NO. 830-024.1 PL REVISION C CUST. CONTR. NO. —				7716 Gary Watson Pt Colorado Springs, CO USA 80915		C 02-11-19 SP SP ADD MOTOR DETAIL				
						B 08-31-18 SP SP CHANGE PART # 800-003				
						REV. DATE: DRWN BY: CHKD BY: DESCRIPTION				
						CUSTOMER P/S -ANGELUS MACHINE				



HTI FILTRATION INC.

7716 Gary Watson Pt. • Colorado Springs, CO 80915 • 719.490.8800 • sales@htifiltration.com

STANDARD WARRANTY

This filter system was inspected before shipment from our plant. To the original purchaser of this system, HTI Filtration warrants its products free from defects in material and workmanship for a period of one (1) year from date of purchase.

HTI Filtration makes no other express warranty and excludes (and buyer waives) any and all implied warranties including, without limitation to, implied warranties in connection with the design, sale, merchantability or fitness of the goods for any particular use or purpose.

In order for any claim under this warranty to be valid, HTI Filtration must receive notice in writing from the buyer within a reasonable time period, not to exceed thirty (30) calendar days after any defect is discovered. The claim must include a detailed report of the conditions of use at the time of discovery of defect. Parts which fail or become defective during the warranty period (except as a result of freezing, melting, improper installation, use or care), shall be replaced or repaired at HTI Filtration's option at no charge within 90 days of the receipt of the defective part, barring unforeseen delays. HTI Filtration shall in no event be responsible for the repairs made by others without the express written permission and consent of HTI Filtration.

To obtain warranty replacement or repairs, defective components or parts should be returned, freight prepaid, to place of purchase or nearest authorized service center. HTI Filtration shall not be responsible for cartage, removal and/or reinstallation labor or any other such costs incurred in obtaining warranty replacements. In no event shall HTI Filtration be responsible for any incidental or consequential damage, whether foreseeable or not and whether or not such damage occurs, or is discovered before or after repair or replacement.

The forgoing warranty does not apply to wear components, seals or filtration elements.

This warranty extends only to the original buyer and HTI Filtration makes no other warranty, expressed or implied, to other persons or entities. If buyer makes any warranty or representation inconsistent with or in addition to the warranty stated hereinabove, the buyer shall, at their own expense, defend and hold HTI Filtration harmless from any claim thereon of any nature whatsoever.