

# **OPERATOR MANUAL**

## **HYDRA-CLEAN FLUID SCRUBBING SYSTEM**

**830-026**

**Zacmi Meccanica**

### **INTRODUCTION:**

Hydra-Clean fluid scrubbing systems are high performance industrial filters designed to remove particulate and water from hydraulic and lubricating oil systems. Manufactured from durable corrosion resistant materials, they are designed for constant uninterrupted use without immediate supervision. The Hydra-Clean 830-026 system utilizes two elements in series to remove water first and then particulate from the working fluid. This system ensures a high degree of fluid purity with an absolute minimum of maintenance and service requirements.

This operating manual is designed to provide you with the basic information to economically and efficiently service your fluid scrubbing system. HTI Filtration welcomes your comments and our technical service staff is available to assist you in applying our equipment to solve your fluid purity problems.

### **SYSTEM OPERATION:**

The Hydra-Supreme 830-026 filtration system uses two separate filtration elements in series to progressively clean the working fluid. Fluid is drawn from the reservoir by a rotary ring gear pump. The fluid is then pushed through the flow sensing and pressure switch assembly into the water removal bag element where the free and emulsified moisture is absorbed. The partially cleaned solution passes through the axial flow depth filter where both soft and hard particulate contamination are removed. The filtered oil then passes back into the closer reservoir. If the contamination level in the oil is high, or if the filters are nearing capacity, several passes through the system may be required for total cleansing of the oil.

The pressure-vacuum gauge on the pump inlet indicates the resistance to flow. It will also register positive pressure if the pump is wired to run backwards.

Typical vacuum readings are from 3 – 10". Any vacuum over 20" can damage the pump. If a high vacuum condition exists there must be a restriction in the oil inlet line that must be cleared for proper pump function.

An internal relief valve that is factory set at 90-PSI controls pump output pressure. The adjustment nut is located adjacent to the left hand/ upper (suction) port of the pump and is an easy way to identify the correct port for oil intake when installing or replacing the pump.

We do *not* recommend tampering with the acorn nut or changing the factory relief setting. Removing the acorn nut without proper tools will result in an intake air leak that will require a new gasket to correct the air leak problem.

The pump output and service life of the two filter elements are monitored by both a flow and a pair of pressure switches. The **flow switch** monitors the volume of oil being pumped through the system. It will trigger an alarm when flow through the system has dropped below the minimum level required for adequate oil cleansing. A flow failure is indicated by the shut off of the red (normal operation) indicator lamp inside the flow switch. The flow switch is factory set at .22-.25 GPM (.83 -.95 l/min) and field adjustment is not advised.

A pair of **pressure switches** monitor the system pressure. Pressure switch settings are field adjustable and should be set to reflect the type of oil used and operating temperatures the filter is working with to receive maximum use from the filters. The initial switch typically activates at 10-12 PSI (.70 Bar) above the start-up pressure and indicates the filter is full and should be replaced. The secondary switch activates at 12-15 PSI (.875 BAR) and indicates **immediate** filter change is required. Complete field adjustment instructions are included in this manual

### **SYSTEM PRESSURES:**

Pressure readings will vary widely with the oil viscosity, ambient air temperature, and temperature of the oil entering the filtration system. It is not unusual for system pressures to rise substantially over normal levels when re-starting a system that has been left off for several days or when changing particulate filters. Typically, the system will return to normal levels after 45-60 minutes as the warm oil from the closer flushes out the cooler oil from the filter elements and the filtration passages in the new element open under pressure. A timed delay in the pressure switch alarm should be programmed in for these reasons. An optional heater blanket assembly can be used to warm the Hydro-Fil bag canister to maintain the desired 95°-100° F operating temperature when the closer is operated in cold temperatures.

### **Factory Set Warning Pressures and Change Out Pressures**

Using Lubriplate SSO-FO-150/Fuchs Cassida GLE 150  
750 SUS/ 156 V.I. synthetic lubricant @ 100°F

Change Filter Switch Maximum- 40 PSI  
Change Filter Switch Maximum- 50 PSI

Typical bag element change out is 10 -12 PSI increase over new element pressure. All measurements should be made when the system is fully warmed to operating pressure.

### **OIL SELECTION INFORMATION:**

HTI Filtration has tested many oils commonly used in closers. While we do not recommend a specific brand or oil type, we do recommend that you use high quality oil that has good hydrolytic stability. That is, oil that can be exposed to water repeatedly and dried without deleting or precipitating the additive package.

The viscosity of the oil plays a major role in determining the operating pressure of the system. 40 Wt. oil rated at 750 SUS at 100°F is actually 2,000 SUS at 75° F, a 260% increase in viscosity! Even small temperature changes can result in significant pressure variations in the system. It is not uncommon for a cold filter system to read higher pressures in the morning and then have them drop off as the system components warm over several hours to an even operating temperature.

### **Field Adjustment of Pressure Switches**

Before changing any settings on a Hydra-Clean Fluid Conditioning System, run the seamer and filter until the oil is at the normal operating temperature (typically between 90-100°F). This typically takes several hours because of the relatively low flow volume and high metal mass of the components.

*NOTE: Do not attempt to reduce or increase the operating pressure by adjusting the internal pressure relief valve on the pump. This safety device has been set and locked into place at the factory. Attempting to adjust the pressure setting screw can jam the relief valve and prevent proper movement. Improperly removing the acorn nut may also result in air leaking into the system, which will require frequent system bleeding until the acorn nut seal is replaced.*

1. Turn filter system on and allow oil to fill both canisters while venting the air through the bleed cocks on the canister lids.
2. As soon as fluid flows from bleed cock, close and secure.
3. Allow filter system to run for 60-120 minutes to flush cold oil out of the filters and bring entire system up to operating temperature. Note the operating pressures of the filters.
4. Slowly close the 1/4" ball valve at the base of the Hydra-Supreme (left hand side) canister until the system pressure is 10-12 PSI higher than the reading in Step 3.
5. Remove cover of warning pressure switch and adjust it by rotating the SET ring until LED illuminates. The RESET ring should be set 5 PSI below the level of the SET ring. Place the cover back on the switch.
6. Repeat with filter replacement switch, then set pressure at 3-4 PSI above warning switch. Open the ball valve to relieve the pressure build-up and allow the system to run for 10-15 minutes before recording the pressures for future reference.

### **PLUMBING:**

Inlet tubing should be  $\frac{3}{4}$ " tubing or hose.  
Transfer lines to and from the canisters should be  $\frac{1}{2}$ "

### **ELECTRICAL:**

The motor utilizes 3 phase, 50/60 Hz power with a number of voltage options.  
Please check the nameplate on your motor if you are unsure of your power type.

The pressure switch and flow sensor come standard, using 24 VDC operating power.

The power source for the filter should be independent of the basic machine control as the oil filtration system should run continuously for efficient contaminant control.

### **INITIAL START-UP PROCEDURE**

Upon completion of the electrical and oil line connections, the Hydra-Clean system is ready for start-up. The 830-026 is factory adjusted to perform with a fluid viscosity of 750 SUS (164 C ST at 40°C) at 100°F. To use different viscosity fluids, or to run at different temperatures, please make the recommended changes to the switch settings. (See the previous section in this manual for further information on adjusting the pressure settings.)

### **FILTER SYSTEM START-UP:**

Crack open the bleed cocks at the top of both canisters. Turn the electrical power on to start the gear pump. If the vacuum gauge shows suction, continue with the startup. If the gauge shows positive pressure, stop the machine and rewire the motor for proper rotation. As soon as fluid starts to flow from the canister top, close the cock securely and wipe the fluid from the canister top. Let the system warm up to the typical operating temperature.

**NOTE:** *Your Hydra-Clean fluid scrubbing system should have no occasion to exceed*

*95 PSI when properly installed and using the recommended type fluid. Should a pressure condition exceed the recommended maximum, immediately shut off the filtering system and contact HTI Filtration for assistance.*

### **Field Setting of Pump Internal Pressure Relief Valve**

The rotary ring gear pump provided with the Hydra-Supreme filtration system is factory set to open at 70-75 PSI and go into full flow bypass at 90 PSI. This system should not be tampered with in the field. If the setting is disturbed, it must be reset to maintain system operating safety.

#### ***To adjust the setting in the field:***

1. Replace any defective parts in the relief valve. See PRV Tech Sheet 4-19-99 for details. If you are sucking air into the system, the valve cap gasket needs to be replaced. This only happens if the valve cap has been loosened and retightened improperly. If this happens, typically, the crush washer will need to be replaced,
2. Bring the system to full operating temperature. If the system will not pump, you need to make sure that the pump is primed. Priming can be accomplished easily by removing the vacuum gauge and squirting oil into the pump inlet.
3. If the pump is primed and still won't generate pressure, you need to turn in the pressure adjusting screw slightly, clockwise, to generate enough spring resistance to close the bypass plunger.
4. With the system running, close the ball valve at the outlet of the left-hand canister to create backpressure on the system. Observe the pressure carefully and open the valve immediately if the pressure rises above 80 PSI. Typically the pump will start relieving internally before it reaches this level.
5. With the system running and the ball valve closed, slowly turn the adjusting screw inwards until the pressure reads between 70-75 PSI. You will hear the bypass valve chattering as you adjust the screw inward. When you reach 70-75 PSI, stop turning the screw and open the ball valve.
6. Slowly close the ball valve again and observe that the pressure relief valve opens at the desired setting of 70-75 PSI. You will hear it and can feel it if you touch the valve body.

7. If the settings are correct, tighten the locknut to hold the screw in place and replace the acorn nut.

## **FILTER ELEMENT REPLACEMENT**

### **800-004 BAG FILTER REPLACEMENT:**

A new bag element should be installed after the system has been in service for 3 months or shows a 10 -12 PSI pressure increases.

- Step 1: Turn off the Filter System. It is not necessary to turn off the seamer to service the filter.
- Step 2: Open the drain cock at the bottom of the bag (left-hand) canister, then open the bleed cock at the top. The 3/8" hose can be used to direct the oil to a container where it can be poured back into the canister for re-use.
- Step 3: Remove the canister clamp ring and lift off the lid.
- Step 4: Examine the "O" ring for wear, replace this ring if it shows signs of wear or if the canister was leaking. A spare "O" ring is shipped with every system.
- Step 5: Slowly lift the bag out by the strap allowing the captured oil to drain back into the canister. Hang the bag over a receptacle if you would like to reclaim the approximately 3 cups of oil entrained in the bag. DO NOT remove the metal support strainer with the bag filter.
- Step 6: Slice open the plastic bag holding the new bag. Carefully remove the bag and straighten to its full length. Slide the new bag into the strainer using the fabric strap to push the metal bag ring down firmly into the strainer. Do not use the fabric strips inside the bag to seat the filter as they will tear off.
- Step 7: Close the drain cock and fill the bag with the drained oil captured in Step 2.
- Step 8: Put the "O" ring back on the canister lip, replace the lid, clamp and tighten.
- Step 9: Start the motor and allow the air to escape through the bleed cock. Close the cock when fluid starts to come out, wipe off the unit and check for leaks.

**800-016 SOLIDS FILTER REPLACEMENT:**

- Step 1: Turn off the Filter System. It is not necessary to turn off the seamer to service the Hydra-Supreme filter.
- Step 2: Open the drain cock on the bottom of the lid, then open the bleed cock on the top of the canister. The 3/8" ID hose can be used to direct the draining oil to a receptacle. Drained oil can later be used to refill the canister.
- Step 3: Remove the canister clamp ring and lift off the canister lid.
- Step 4: Examine the canister "O" ring for cracks and wear spots. If the canister lid seal was leaking, or if the "O" ring shows signs of wear, replace the ring.
- Step 5: Unscrew the "T" handle assembly (CCW) that holds the filter in place. The cup seal on the handle assembly should be smooth and free of rough spots or tears. Replacement seals are available.
- Step 6: Slice open the end of the plastic bag holding the new element. Remove the new element and set in a clean area. Lift used element off of center post and place it in a receptacle to drain free of oil.
- Step 7: Slide new element over the center post. Make sure the metal bale is at the top. Secure the element with the "T" handle.
- Step 8: Close drain cock and refill canister with oil.
- Step 9: Put the "O" ring back on the canister lip, replace lid, clamp and tighten.
- Step 10: Start the pump motor and allow air to bleed out through bleed cock on top of canister. Close bleed cock when fluid starts to come out.  
Wipe off unit and check for leaks.

**CAUTION!**

Some hydrocarbon oils are not suitable for extended use after they have been mixed with water. These non-hydrolytically stable lubricants tend to precipitate out their additives, which are captured by the Hydra-Supreme axial filter element. These oils look acceptable, but no longer have the original anti-wear and anti-oxidization characteristics of new oil.



HTI Filtration recommends that you use a premium grade lubricant whenever you have an on-going water contamination problem and that you consult your lubricant supplier for specific information on your specified oil.

### **OIL DRAINING AND FLUSHING**

To replace existing type of oil or to flush the filtration system HTI recommends the following actions.

1. Turn off the system and allow all pressure to dissipate.
2. Open the drain cocks and bleed cocks on both of the canisters and allow the oil to drain completely. Air pressure can be gently applied at the top of the canisters to aid draining.
3. Remove both the bag and axial flow elements.
4. Unscrew the pressure switches from the system and allow the oil to drain from the sensor array and filter inlet hose.
5. Break the hose loose from the filtration system inlet and let it drain free of oil.
6. Replace all hoses, sensors, and filters when ready to recharge with oil or to flush.
7. Repeat the draining process after flushing.

This process will not remove all of the oil, but will remove as much as is feasible.

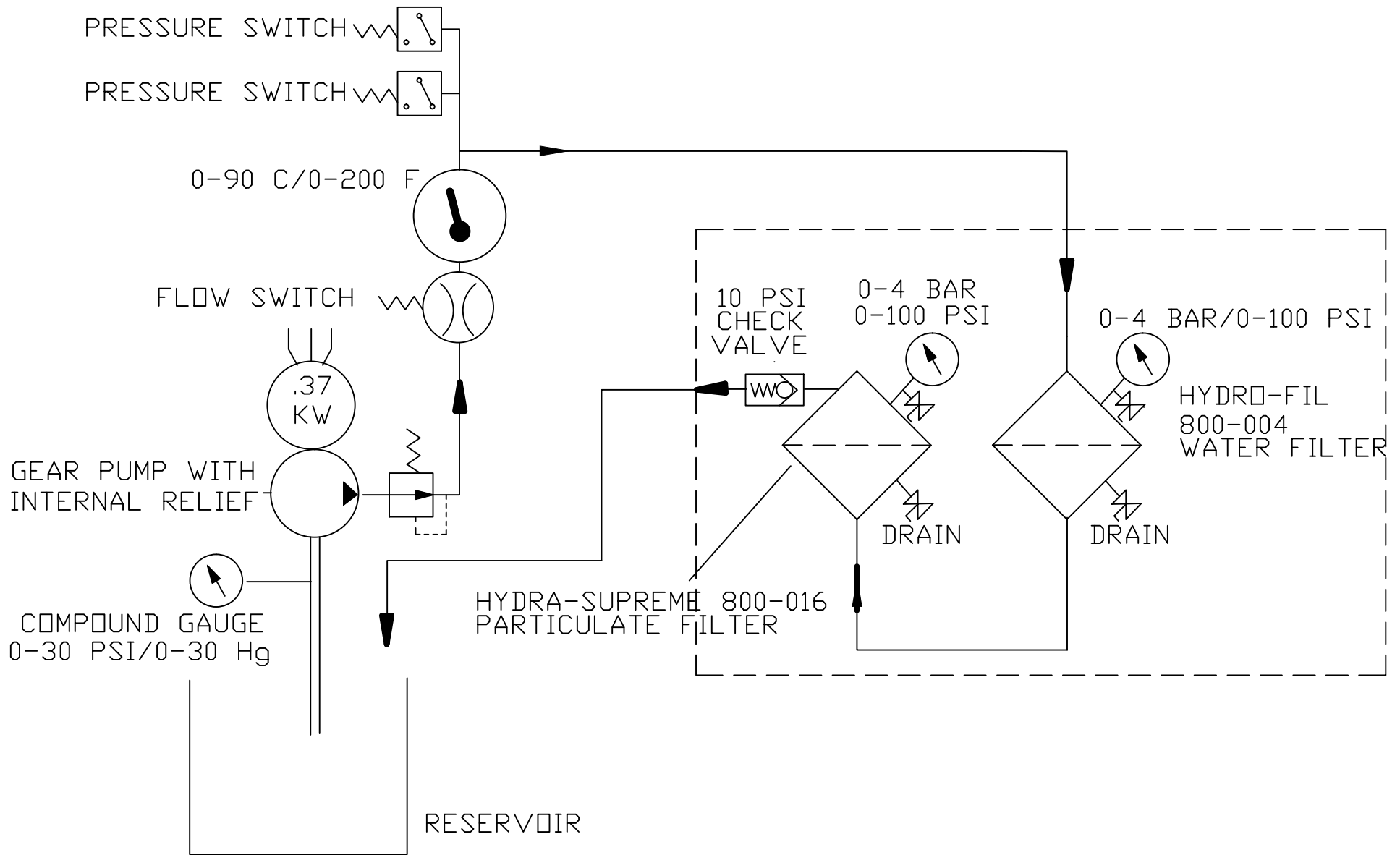

DWG. TITLE <b>830-026 FLOW SCHEMATIC</b>				HTI FILTRATION INC.  7716 Gary Watson Pt Colorado Springs CO 80915		830-026 FILTRATION FLOW SCHEMATIC				
PROJECT DESCRIPTION <b>SEAMER PARTICULATE AND WATER REMOVAL SYSTEM</b>						0	11-23-2022	SP	RH	ORIGINAL ISSUE
JOB NO. -	DRAWING NO. 830-026FS	REVISION 0	CUST. CONTR. NO. -	REV.	DATE:	DRWN BY	CHKD BY	DESCRIPTION		
CUSTOMER						ZACMI				

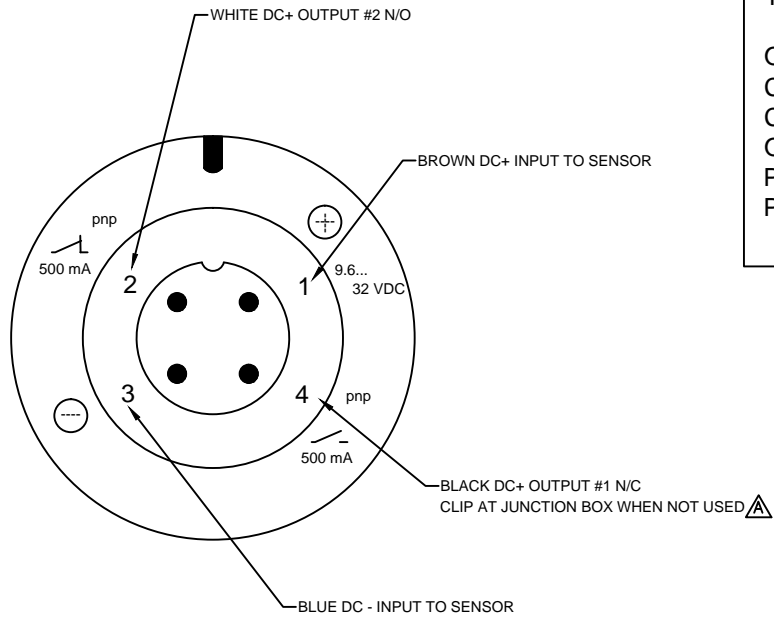

TECHNICAL DATA -	
OPERATING VOLTAGE -	9.6 TO 32 VDC
CURRENT RATING (mA) -	500
CURRENT CONSUMPTION -	<25
OPERATING TEMPERATURE -	-25 TO 80 C
PROTECTION -	IP 67 / III
PRESSURE RANGE-	0...10 BAR 0...145 PSI

NOTE:  
 USE 620-005 RIGHT ANGLE CONNECTOR  
 M12 micro DC (4 pin) 5m 22 AWG, Black  
 PUR jacket

USE 620-006 CLEAR COVER

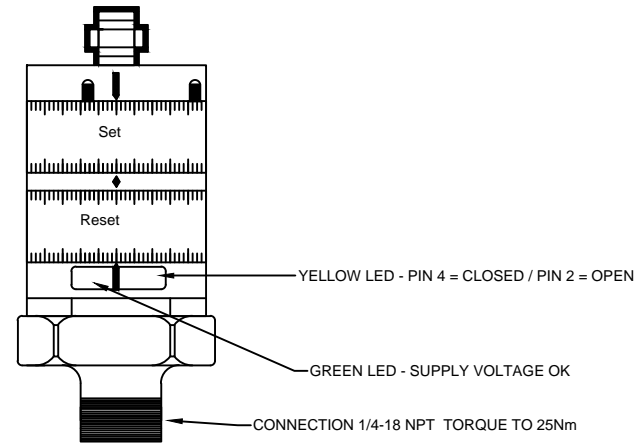

DWG. TITLE PRESSURE SWITCH ILLUSTRATION				HTI FILTRATION						
PROJECT DESCRIPTION PRESSURE SWITCH 620-004						7716 GARY WATSON PT COLORADO SPRINGS CO 80915		A	02-20-24	SP
JOB NO.	DRAWING NO.	REVISION	CUST. CONTR. NO.			0	08-10-12	SP	SP	ORIGINAL ISSUE
-	620-004	A	-			REV.	DATE:	DRWN BY	CHKD BY	DESCRIPTION
						CUSTOMER				

## TROUBLESHOOTING GUIDE

### HYDRA-SUPREME MODEL 830-026

When using this guide please remember that all pressure and flow readings are to be taken with the system at normal operating temperatures.

<b>SYMPTOM</b>	<b>CAUSE</b>	<b>CORRECTIVE ACTION</b>
ERRATIC FLOW RATE, BUBBLES IN OIL STREAM	AIR LEAK IN FITTINGS, BLEED COCK OR VACUUM GAUGE	CONFIRM THAT VACUUM BLEED AND GAUGE ARE AIR TIGHT, CHECK FITTINGS
	AIR LEAK UNDER RELIEF PUMP ADJUSTMENT NUT	MAKE SURE TORQUE STRIPE ON ACORN NUT IS INTACT, REPLACE SEAL IF BROKEN
	LOOSE OR PINCHED FEED TUBE CONNECTION	MAKE SURE ALL PLUMBING CONNECTIONS ARE TIGHT
	LOW FLUID LEVEL	CHECK FLUID LEVEL IN RESERVOIR
EXCESSIVE VACUUM (ABOVE 15")	FLOW RESTRICTION	CHECK INLET PIPING FOR RESTRICTION, BLOCKAGE
	INLET PIPING RESTRICTION	CONFIRM 3/4"-1" INLET PIPING SIZE
	OIL TOO THICK (OVER 900 SUS @100°F)	CHANGE TO LIGHTER GRADE OF OIL
	ENVIRONMENT TOO COLD - LESS THAN 60° FARENHEIT	INSULATE FEED LINE TO FILTER, HEAT CANISTERS
	SEAMER RUNS TOO COLD-OIL DOESNT' GET OVER 80° F.	CHANGE TO LIGHTER GRADE OIL
	AMBIENT AIR AND SEAMER TEMPERATURE UNDER 80° F.	INSTALL HEAT BLANKET ON FILTER CANISTER
LOW FLOW RATE WITH LOW PRESSURE	AIR BUBBLE IN PUMP	OPEN AIR VENTS TO BLEED OF AIR
	INSUFFICIENT MOTOR POWER GENERATED	CHECK FOR PROPER PUMP VOLTAGE AND ROTATION
	OIL BYPASSING THROUGH RELIEF VALVE	CHECK RELIEF VALVE FOR PROPER SETTING

<b>SYMPTOM</b>	<b>CAUSE</b>	<b>CORRECTIVE ACTION</b>
LOW FLOW RATE WITH HIGH PRESSURE	LOADED FILTER	REPLACE FILTER ELEMENT
	RESTRICTED OUTLET LINES	CHECK AND CLEAR RETURN LINES
EXCESSIVE PRESSURE	RELIEF VALVE SET TOO HIGH	CHANGE FILTER AND RE-SET RELIEF VALVE TO 65 PSI
PUMP WON'T WORK AFTER ELEMENT CHANGE OR STRAINER CLEANING	VACUUM LOCK IN PUMP	BLEED AIR OFF AT BLEED VALVE ON PUMP OUTLET
UPPER TURRET OR LUBRICATOR WON'T FILL	FAULTY SOLENOID COIL	CHECK COIL ON SOLENOID, REPLACE IF DEFECTIVE
CANISTERS LEAK AT LID CLAMP	CUT OR ERODED SEAL	CHECK SEALS FOR DAMAGE
	LID NOT TIGHT	TIGHTEN CLAMP BOLT

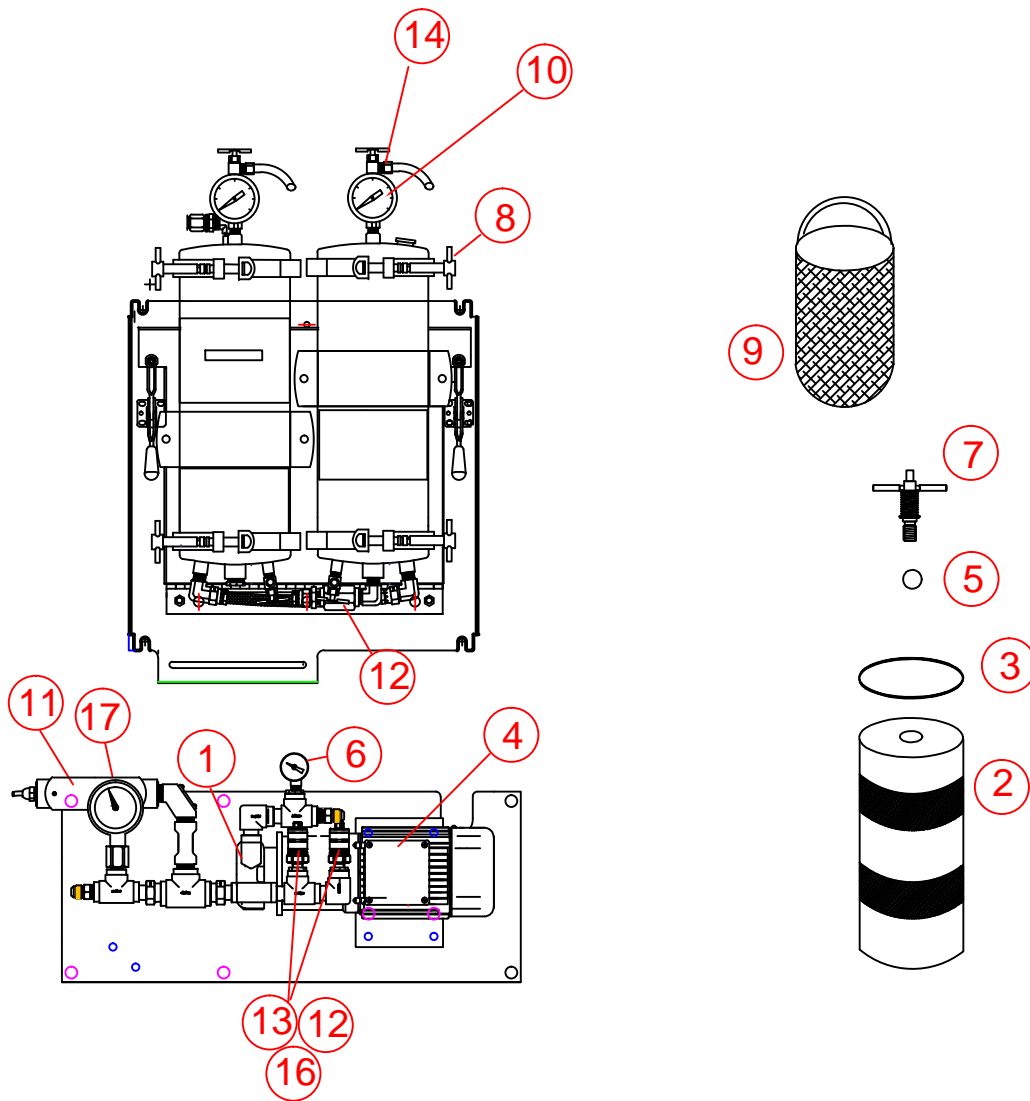

PARTS LIST

ITEM NO.	DESCRIPTION	DWG. NO
1	PUMP	770-013.1
2	SOLIDS FILTER	800-016
3	CANISTER O-RING	450-002
4	MOTOR 3 PHASE 50/60 HZ .33 HP/.25 Kw 1700 RPM	780-029
5	T-HANDLE SEAL	450-003
6	COMPOUND GAUGE	610-013
7	T-HANDLE	860-001
8	CLAMP ASSEMBLY	540-005
9	WATER ABSORPTION BAG	800-004
10	PRESSURE INDICATOR	610-010
11	FLOW SENSOR	620-010
12	PRESSURE SWITCH CABLE	620-005
13	PRESSURE SWITCH	620-004
14	BLEED/DRAIN VALVE	430-075
15	CHECK VALVE	430-079
16	PRESSURE SWITCH COVER	620-006
17	TEMPERATURE GAUGE	640-001

DWG. TITLE 830-026				HTI INC.		SPARE PARTS LIST				
PROJECT DESCRIPTION LUBRICATING OIL FILTRATION SYSTEM				7716 Gary Watson Pt Colorado Springs CO 80915		-	-	-	-	-
JOB NO.	DRAWING NO.	REVISION	CUST. CONTR. NO.			0	03/14/23	SP	SP	FIRST ISSUE
-	830-026PL	0	-	REV.	DATE:	DRWN BY	CHKD BY	DESCRIPTION		
CUSTOMER						Zanicelli Meccanica				



**HTI FILTRATION INC.**

---

**7716 Gary Watson Pt. • Colorado Springs, CO 80915 • 719.490.8800 • sales@htifiltration.com**

## **STANDARD WARRANTY**

This filter system was inspected before shipment from our plant. To the original purchaser of this system, HTI Filtration warrants its products free from defects in material and workmanship for a period of one (1) year from date of purchase.

HTI Filtration makes no other express warranty and excludes (and buyer waives) any and all implied warranties including, without limitation to, implied warranties in connection with the design, sale, merchantability or fitness of the goods for any particular use or purpose.

In order for any claim under this warranty to be valid, HTI Filtration must receive notice in writing from the buyer within a reasonable time period, not to exceed thirty (30) calendar days after any defect is discovered. The claim must include a detailed report of the conditions of use at the time of discovery of defect. Parts which fail or become defective during the warranty period (except as a result of freezing, melting, improper installation, use or care), shall be replaced or repaired at HTI Filtration's option at no charge within 90 days of the receipt of the defective part, barring unforeseen delays. HTI Filtration shall in no event be responsible for the repairs made by others without the express written permission and consent of HTI Filtration.

To obtain warranty replacement or repairs, defective components or parts should be returned, freight prepaid, to place of purchase or nearest authorized service center. HTI Filtration shall not be responsible for cartage, removal and/or reinstallation labor or any other such costs incurred in obtaining warranty replacements. In no event shall HTI Filtration be responsible for any incidental or consequential damage, whether foreseeable or not and whether or not such damage occurs, or is discovered before or after repair or replacement.

The forgoing warranty does not apply to wear components, seals or filtration elements.

This warranty extends only to the original buyer and HTI Filtration makes no other warranty, expressed or implied, to other persons or entities. If buyer makes any warranty or representation inconsistent with or in addition to the warranty stated hereinabove, the buyer shall, at their own expense, defend and hold HTI Filtration harmless from any claim thereon of any nature whatsoever.