

OPERATOR MANUAL

HYDRA-CLEAN FLUID SCRUBBING SYSTEM

830-001.3.1-R-9

Angelus F029H614

INTRODUCTION:

Hydra-Clean fluid scrubbing systems are high performance industrial filters designed to remove particulate and water from hydraulic and lubricating oil systems. Manufactured from durable corrosion resistant materials, they are designed for constant uninterrupted use without immediate supervision. The Hydra-Clean 830-001.3.1 system utilizes two elements in series to remove water, and then particulate from the working fluid. This system ensures a high degree of fluid purity with an absolute minimum of maintenance and service requirements.

This operating manual is designed to provide you with the basic information to economically and efficiently service your fluid scrubbing system. HTI Filtration welcomes your comments and our technical service staff is available to assist you in applying our equipment to solve your fluid purity problems.

SYSTEM OPERATION:

The Hydra-Supreme 830-001.3.1 filtration system uses two separate filtration elements in series to progressively clean the working fluid. Fluid is drawn from the reservoir up through a check valve by a rotary pump. The fluid is then pushed through the digital temperature sensor ,flow meter and digital pressure sensor assembly into the water removal bag element where the free and emulsified moisture are absorbed. The partially cleaned solution passes through the axial flow depth filter where both soft and hard particulate contamination are removed. The filtered oil then passes through a solenoid operated selector valve and back into the seamer, the pressurized lubrication system reservoir, or through another solenoid where upper turret oil flush (boost) is utilized. If the contamination level in the oil is high, or if the filters are nearing capacity, several passes through the system may be required for total cleansing of the oil.

The gravity check valve at the pump inlet ensures adequate oil supply to wet the pump during start-up and prevents drain back when the system is shut-off. There is NO strainer assembly in this valve and none should ever be installed. The combination pressure - vacuum gauge indicates both the motor rotation direction (sucking or pushing the oil) and the resistance to flow. **This gauge assembly has a manual bleed cock that should be cracked open for safety relief during initial start-up if by chance the motor is rotating backwards.**

Typical vacuum readings are from 3 – 10". Any vacuum over 20" can damage the pump. If a vacuum condition over 15" is seen during normal operation, HTI recommends that a booster pump (HTI Assembly 460-064.2) be utilized at the seamer base. The secondary bleed cock located on the outlet elbow of the pump is to relieve entrapped air from the pump chamber. Opening this bleed cock creates a low outlet pressure state that allows any trapped air to be discharged and allows oil to be drawn in to restore pump suction. To remove the air, simply crack open the bleed cock with the motor running and leave it open until oil begins to flow out of it.

An internal relief valve that is factory set at 90-PSI controls pump output pressure. The adjustment nut is located adjacent to the left hand (suction) port of the pump and is an easy way to identify the correct port for oil intake when installing or replacing the pump head. We do *not* recommend tampering with the acorn nut or changing the factory relief setting. Removing the acorn nut without proper tools will result in an intake air leak that will require a new gasket to correct the air leak problem.

The pump output and service life of the two filter elements are monitored by a flow and pressure sensor. The flow sensor monitors the volume of oil being pumped through the system. It will trigger an alarm when flow through the system has dropped below the minimum level required for adequate oil cleansing and replenishment of the seamer lubrication pump reservoir. A flow failure is indicated by the red "no oil flow" light on the main panel and the shut off of the red, normal operation, indicator lamp inside the flow switch. The flow switch is factory set at .22-.25 GPM (.83 -.95 l/min) and field adjustment is not advised. A digital pressure sensor has a pair of pressure switches that monitor and display the system pressure. System pressures within normal operating range are displayed in green LED numerals and anything outside normal is displayed in red LED numerals. The initial switch level activates the "Warning Filter Pressure" light and the second lights up the amber "Maximum Pressure" light on the main panel. Pressure switch settings are field adjustable and should be set to reflect the type of oil used and operating temperatures the filter is working with to receive maximum use from the filters. The initial switch typically activates at 9-10 PSI (.7 Bar) above the start-up pressure and the Change Filter light illuminates at 5-10 PSI (.7 Bar) above that setting. Settings are best changed using the ifm Efector ZZ1060 Interlink Software package and connecting cable but manual adjustments can also be made using the push buttons on the sensor face. Complete field adjustment instructions are included in this manual.

The selector solenoid valve is operated by remote sensing switches and timers, which vary depending on which options are selected at the time of order. The maximum line resistance pressure on the diverter pump should be less than 25 PSI (1.75 Bar) when the valve is activated.

SYSTEM PRESSURES:

Pressure readings will vary widely with the oil viscosity, ambient air temperature, and temperature of the oil entering the filtration system. It is also not unusual for system pressures to rise substantially over normal levels when re-starting a system that has been left off for several days or when changing particulate filters. Typically, the system will return to normal levels after 45-60 minutes as the warm oil from the seamer flushes out the cooler oil from the filter elements and the filtration passages in the new element open under pressure. A timed delay in the pressure switch alarms has been programmed in for these reasons. In cold climates it may be necessary to apply the optional heater blanket to warm the Hydro-Fil bag canister to maintain the desired 95°-100° F operating temperature.

Factory Set Warning Pressures and Change Out Pressures

Using Lubriplate SSO-FO-150/Fuchs Cassida GLE 150
750 SUS/ 156 V.I. synthetic lubricant @ 100°F

Warning Switch - 65 PSI Change Filter Switch - 70 PSI

Typical bag element change out is 10 -12 PSI increase over new element pressure. All measurements should be made when the system is fully warmed to operating pressure.

OIL SELECTION INFORMATION:

HTI Filtration has tested many oils commonly used in seamers. While we do not recommend a specific brand or oil type, we do recommend that you use high quality oil that has good hydrolytic stability. That is, oil that can be exposed to water repeatedly and dried without deleting or precipitating the additive package.

The viscosity of the oil plays a major role in determining the operating pressure of the system. 40 Wt. oil rated at 750 SUS at 100°F is actually 2,000 SUS at 75° F, a 260% increase in viscosity! Even small temperature changes can result in significant pressure variations in the system. It is not uncommon for a cold filter system to read higher pressures in the morning and then have them drop off as the system components warm over several hours to an even operating temperature.

Field Adjustment of Pressure Switches

Before changing any settings on a Hydra-Clean Fluid Conditioning System, run the seamer and filter until the oil is at the normal operating temperature (typically between 90-100°F). This typically takes several hours because of the relatively low flow volume and high metal mass of the components.

NOTE: Do not attempt to reduce or increase the operating pressure by adjusting the internal pressure relief valve on the pump. This safety device has been set and locked into place at the factory. Attempting to adjust the pressure setting screw can jam the relief valve and prevent proper movement. Improperly removing the acorn nut may also result in air leaking into the system, which will require frequent system bleeding until the acorn nut seal is replaced.

Field adjustment instructions are included with this manual. HTI recommends that a laptop computer with the ifm Efector ZZ1060 Interlink system be utilized but manual adjustment can be performed using the 3 push buttons on the sensor face.

SYSTEM LOCATION:

Although the Hydra-Clean system uses a self-priming pump, it is advisable to keep the filter below and as close to the reservoir as possible. A suction line vacuum condition no greater than 20"hg should be experienced during start-up or normal operation. Pump damage will occur at vacuum levels above 24" hg.

Where the filter is remotely mounted from the seamer or there is significant piping and the pump vacuum exceeds 15" HTI recommends the installation of a booster pump at the seamer reservoir to deliver the oil to the filter pump. The booster pump should deliver a maximum of 15-PSI pressure. Remote mounted filters will also experience higher-pressure readings due to the increased return line resistance.

Set the filtration system cabinet on a solid, level surface. Allow a minimum of 24" of frontal clearance for service access. Locate filter away from sources of moisture and heat, filter system must be kept below 140°F, and be protected from moisture.

PLUMBING:

Inlet tubing should be ¾" with a preferred maximum distance of 20'. Smaller tubing can be

utilized where the connection runs are shorter and/or the operating temperature is above 80° F.

The two return ports utilize 3/4" JIC fittings. Flow selection is determined by remote activation of the solenoid valve from the main control panel. Outlet lines to the main reservoir and lubricating system should be 3/4", with a preferred maximum length of 20'-0". Ball valves can be installed at both reservoir connections for easy shut off during installation or service.

ELECTRICAL:

The motor utilizes 3 phase, 50/60 Hz power with a number of voltage options. Please check the nameplate on your motor if you are unsure of your power type.

The solenoid coil, pressure switches, and flow sensor come standard using 24 VDC operating power. 120 VAC power is optional for the solenoid.

The power source for the filter should be independent of the basic machine control, as the oil filtration system should run continuously for efficient contaminant control.

INITIAL START-UP PROCEDURE

Upon completion of the electrical and hydraulic connections, the Hydra-Clean system is ready for start-up. The 830-001.3.1 is factory adjusted to perform with a fluid viscosity of 750 SUS (164 C ST at 40°C) at 100°F. To use different viscosity fluids, or to run at different temperatures, please make the recommended changes to the switch settings. (See the previous section in this manual for further information on adjusting the pressure settings.)

FILTER SYSTEM START-UP:

Crack open the bleed cock at the compound gauge next to the pump inlet a small amount. Make sure the inlet and return lines to the reservoir are free of restriction and all valves are open. Crack open the bleed cocks at the top of both canisters. Turn the electrical power on to start the gear pump. If the vacuum gauge shows suction, quickly close that bleed cock and continue with the startup. If air/oil is pushed out of the bleed, cock shut off the system and rewire the motor for proper rotation. As soon as fluid starts to flow from the canister top, close the cock securely and wipe the fluid from the canister top. Let the system warm up to typical operating temperature.

When initially starting the Hydra-Clean system, air may enter the plumbing lines in sufficient quantity to keep the pump from priming itself or create a false reading in the oil flow sensor. Should this occur, you must bleed off this trapped air by opening the bleed cock located at the pump outlet elbow just above the union.

NOTE: *Your Hydra-Clean fluid scrubbing system should have no occasion to exceed 95 PSI when properly installed and using the recommended type fluid. Should a pressure condition exceed the recommended maximum, immediately shut off the filtering system and contact HTI Filtration for assistance.*

Field Setting of Pump Internal Pressure Relief Valve

The rotary ring gear pump provided with the Hydra-Supreme filtration system is factory set to open at 70-75 PSI and go into full flow bypass at 90 PSI. This system should not be tampered with in the field. If the setting is disturbed it must be reset to maintain system operating safety.

To adjust the setting in the field:

1. Replace any defective parts in the relief valve. See PRV Tech Sheet 4-19-99 for details. If you are sucking air into the system, the valve cap gasket needs to be replaced. This only happens if the valve cap has been loosened and cannot be corrected by just tightening the nut again.
2. Bring the system to full operating temperature.
If the system will not pump, you need to make sure that the pump is primed. Priming can be accomplished easily by removing the vacuum gauge and squirting oil into the pump inlet.

Make sure the petcock on the vacuum pump stem is closed.
You should also vent any air trapped in the pump chamber by opening the vent on the pump outlet while the pump is running.
3. If the pump is primed and still won't generate pressure, you need to turn in the pressure adjusting screw slightly, clockwise to generate enough spring resistance to close the bypass plunger.
4. With the system running, close the ball valve at the outlet of the left hand canister to create backpressure on the system. Observe the pressure carefully and open the valve immediately if the pressure rises above 80 PSI. Typically the pump will start

relieving internally before it reaches this level.

5. With the system running and the ball valve closed, slowly turn the adjusting screw inwards until the pressure reads between 70-75 PSI. You will hear the bypass valve chattering as you adjust the screw inward. When you reach 70-75 PSI stop turning the screw and open the ball valve.
6. Slowly close the ball valve again and observe that the pressure relief valve opens at the desired setting of 70-75 PSI. You will hear it and can feel it if you touch the valve body.
7. If the settings are correct, you can tighten the locknut to hold the screw in place and replace the acorn nut.

FILTER ELEMENT REPLACEMENT

BAG FILTER REPLACEMENT:

A new bag element should be installed after the system has been in service for 3 months or shows a 10 -12 PSI pressure increases.

- Step 1: Turn off the Filter System. It is not necessary to turn off the seamer to service the filter.
- Step 2: Open the drain cock at the bottom of the bag (right hand) canister then open the bleed cock at the top. The 3/8" hose can be used to direct the oil to a container where it can be poured back into the canister for re-use.
- Step 3: Remove the canister clamp ring and lift off the lid.
- Step 4: Examine the "O" ring for wear, replace this ring if it shows signs of wear or if the canister was leaking. A spare "O" ring is shipped with every system.
- Step 5: Slowly lift the bag out by the strap allowing the captured oil to drain back into the canister. Hang the bag over a receptacle if you want to reclaim the approximately 3 cups of oil entrained in the bag. Do Not remove the metal support strainer with the bag filter.
- Step 6: Slice open the plastic bag holding the new bag. Carefully remove the bag and straighten to its full length. Slide the new bag into the strainer using the

fabric strap to push the metal bag ring down firmly onto the seat. Do not use the fabric strips inside the bag to seat the filter as they will tear off.

- Step 7: Close the drain cock and fill the bag with the drained oil captured in Step 2.
- Step 8: Put the "O" ring back on the canister lip, replace the lid, clamp and tighten.
- Step 9: Start the motor and allow the air to escape through the bleed cock. Close the cock when fluid starts to come out, wipe off the unit and check for leaks.

SOLIDS FILTER REPLACEMENT:

- Step 1: Turn off the Filter System. It is not necessary to turn off the seamer to service the Hydra-Supreme filter.
- Step 2: Open the drain cock on the bottom of the lid, then open the bleed cock on the top of the canister. The 3/8" ID hose can be used to direct the draining oil to a receptacle. Drained oil can later be used to refill the canister.
- Step 3: Remove the canister clamp ring and lift off the canister lid.
- Step 4: Examine the canister "O" ring for cracks and wear spots. If the canister lid seal was leaking, or if the "O" ring shows signs of wear, replace the ring.
- Step 5: Unscrew the "T" handle assembly (CCW) that holds the filter in place. The cup seal on the handle assembly should be smooth and free of rough spots or tears. Replacement seals are available.
- Step 6: Slice open the end of the plastic bag holding the new element. Remove the new element and set in a clean area. Lift used element off of center post and place it in a receptacle to drain free of oil.
- Step 7: Slide new element over the center post. Make sure the metal bale is at the top. Secure the element with the "T" handle.
- Step 8: Close drain cock and refill canister with oil.
- Step 9: Put the "O" ring back on the canister lip, replace lid, clamp and tighten.
- Step 10: Start the pump motor and allow air to bleed out through bleed cock on top of canister. Close bleed cock when fluid starts to come out. Wipe off unit and check for leaks.

CAUTION!

Some hydrocarbon oils are not suitable for extended use after they have been mixed with water. These non-hydrolytically stable lubricants tend to precipitate out their additives, which are captured by the Hydra-Supreme axial filter element. These oils look acceptable but no longer have the original anti-wear and anti-oxidization characteristics of new oil.

HTI Filtration recommends that you use a premium grade lubricant whenever you have an on-going water contamination problem and that you consult your lubricant supplier for specific information on your specified oil.

OIL DRAINING AND FLUSHING

To replace existing type of oil or to flush the filtration system HTI recommends the following actions.

1. Turn off the system and allow all pressure to dissipate.
2. Open the drain cocks and bleed cocks on both of the canisters and allow the oil to drain completely. Air pressure can be gently applied at the top of the canisters to aid draining.
3. Remove both the bag and axial flow elements.
4. Unscrew one of the pressure switches from the system and allow the oil to drain from the sensor array and filter inlet hose.
5. Break hoses loose from the check valve and solenoid valves to let them drain free of oil.
6. Replace all hoses, sensors and filters when ready to recharge with oil or to flush. Repeat the draining process after flushing.

This process will not remove all of the oil, but will remove as much as is feasible.

**ANGELUS F029H614 FILTRATION SYSTEM
HTI # 830-001.3**

**FLOW SENSOR ELECTRONICS-
RED LIGHT INDICATES ALARM
CONDITION. UNIT IS PRE-SET
AND SHOULD NOT BE ADJUSTED
IN THE FIELD.**

**OIL TEMPERATURE-
SHOULD BE BETWEEN 80
F AND 110 F. IF LOWER
ADD HEATER BLANKET
KIT 460-003 TO SYSTEM**

**VACUUM/PRESSURE GAUGE-
OPEN PETCOCK AT STARTUP
TO PREVENT DAMAGE IN
CASE MOTOR IS WIRED
BACKWARDS .OPERATING
VACUUM SHOULD BE 0-15 "**

**GRAVITY CHECK VALVE- KEEPS
PUMP PRIMED. NOT A
STRAINER TYPE**

**ROTARY RING GEAR PUMP - DO NOT OPEN OR
TAMPER WITH THE ACORN NUT ASSEMBLY. IT
WILL SUCK AIR UNTIL BOTH METAL SEALS ARE
REPLACED IF TAMPERED WITH.
CANNOT BE USED TO ADJUST PRESSURE
WILL GO INTO FULL BYPASS AT 90 PSI**



**PRESSURE GAUGES SHOULD NEVER EXCEED 65 PSI.
CHANGE BAG FILTER 10-12 PSI OVER START-UP
PRESSURE - CHANGE SOLID FILTER 20-25 PSI OVER
STARTUP PRESSURE**

**HYDRA-SUPREME- SOLID FILTER
REMOVES SOLIDS AND SEMI-
SOLIDS FROM OIL STREAM**

**HYDRO-FIL BAG FILTER - REMOVES
WATER FROM OIL STREAM**

**NO/NC SOLENOID VALVE- THESE
DIRECT THE FLOW TO THE TURRET,
RESERVOIR, TRABON RESERVOIR OR
SECOND SOLENOID VALVE.**

**FLOW SENSOR HEAD - MONITORS
THE FLOW OF OIL AND TRIGGERS
ALARM AT .25 GPM. INDICATES
FULL FILTER, LEAK OR LOSS OF
PUMP POWER.**

**PRESSURE SWITCH - EXTERNALLY
ADJUSTABLE WITH POWER AND ALARM
LED LIGHTS. SET "CHECK FILTER" AT 10
PSI ABOVE BAG START-UP PRESSURE,
SET "CHANGE FILTER" AT 12 PSI ABOVE.**

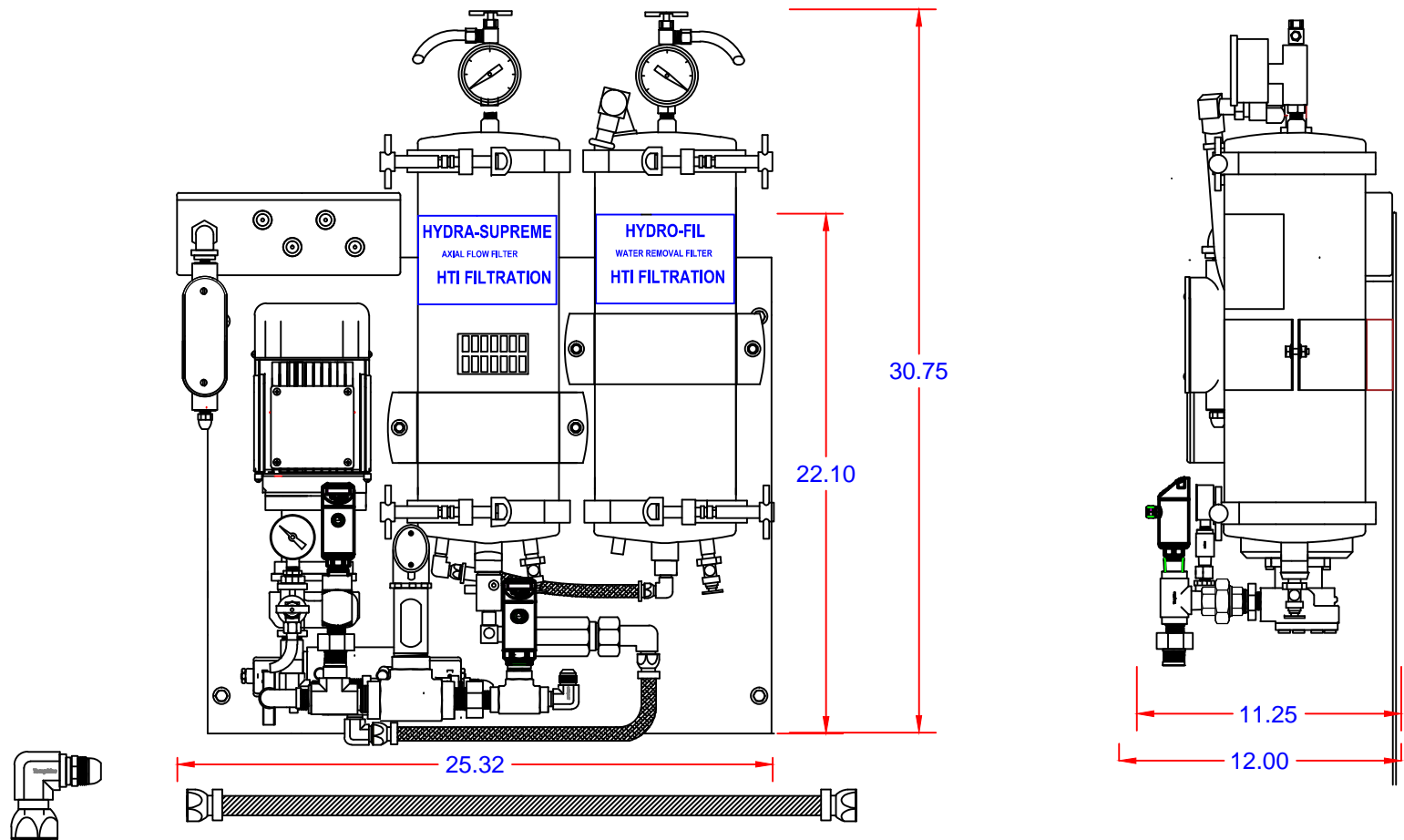

DWG. TITLE 830-001.3.1 R-9				HTI FILTRATION INC. 7716 GARY WATSON PT COLORADO SPRINGS COLORADO USA 80915		830-001.3.1 R-9				
PROJECT DESCRIPTION ANGELUS F0029H614 AACW						0	06-02-21	SP	SP	FIRST ISSUE
JOB NO.	DRAWING NO.	REVISION	CUST. CONTR. NO.	REV.	DATE:	DRWN BY	CHKD BY	DESCRIPTION		
—	830-001.3.1	R-9	—					CUSTOMER PNEUMATIC SCALE -ANGELUS		

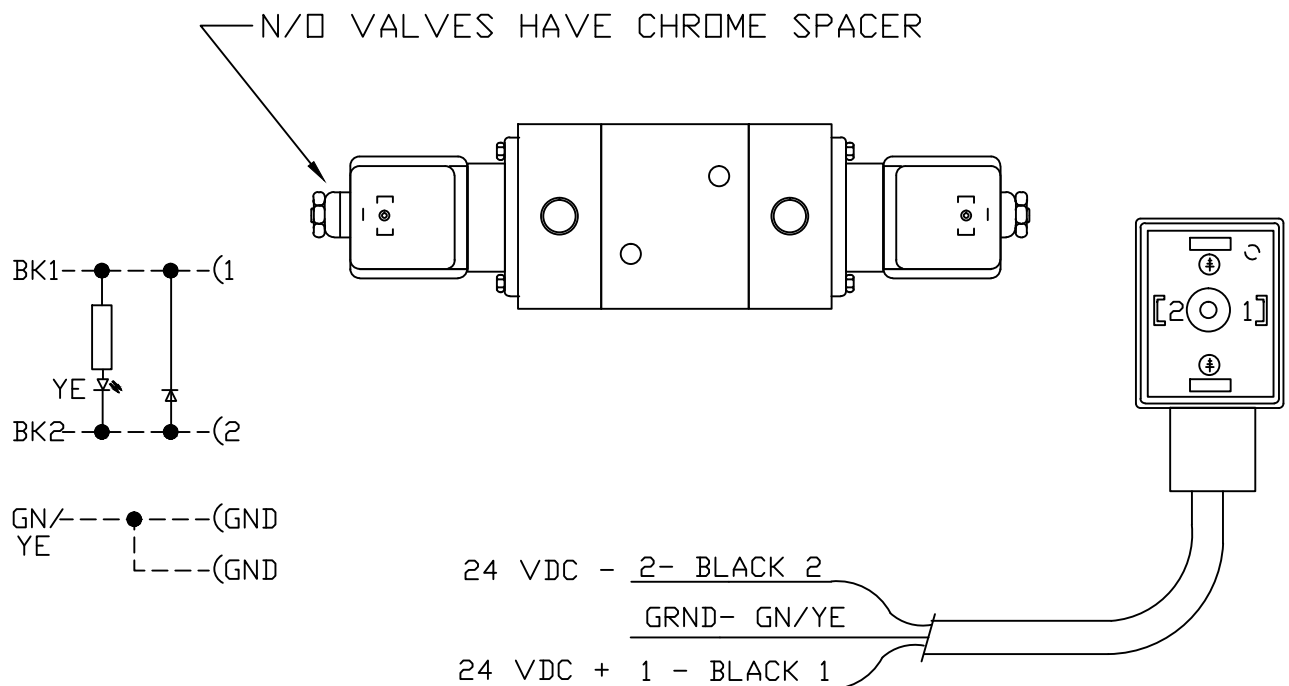

DIN CONNECTOR WITH RECTIFIER-
 - HTI PART 250-019

COIL DATA:
 0.417 AMPS INRUSH & HOLDING, 10 WATTS CONSTANT
 COILS ARE NON-RECTIFIED-

DWG. TITLE SOLENOID WIRING				HTI FILTRATION		250-019 DIN CONNECTOR SOLENOID VALVE WIRING					
PROJECT DESCRIPTION 430-068,074,083 SOLENOID VALVE WIRING DIAGRAM				7716 Gary Watson pt Colorado Springs Colorado, USA, 80915		0	12-10-05	SCP	RAH	ORIGINAL ISSUE	
JOB NO.	DRAWING NO.	REVISION	CUST. CONTR. NO.			REV.	DATE:	DRWN BY	CHKD BY	DESCRIPTION	
-	430-068 WD	0	-			CUSTOMER KHS					

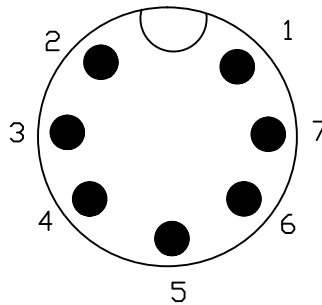
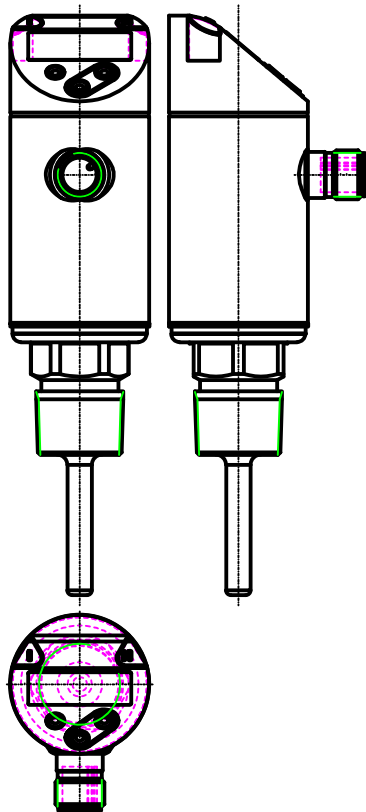

PROGRAMING OF SWITCH OUTPUTS:

Hno = HYSTERESIS IS / NO

Hnc = HYSTERESIS IS/ NC

Fno = WINDOW / NO

Fnc = WINDOW / NC

ELECTRICAL DATA-

DESIGN - DC PNP

OPERATING VOLTAGE - 18..30 VDC

CURRENT CONSUMPTION I_{max} <80

PROTECTION CLASS III

REVERSE POLARITY PROTECTION - YES

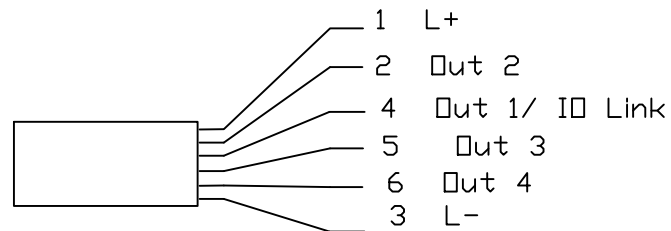

DWG. TITLE		HTI			
TEMPERATURE SENSOR ILLUSTRATION		FILTRATION			
PROJECT DESCRIPTION		7716 Gary Watson Pt Colorado Springs Colorado, USA, 80915		0	03-10-21
TEMPERATURE SENSOR 640-004				SP	SP
JOB NO.	DRAWING NO.	REVISION	CUST. CONTR. NO.	ORIGINAL ISSUE	
-	640-004		-	REV.	DATE:
				DRWN BY	CHKD BY
				DESCRIPTION	
				CUSTOMER	

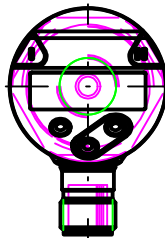
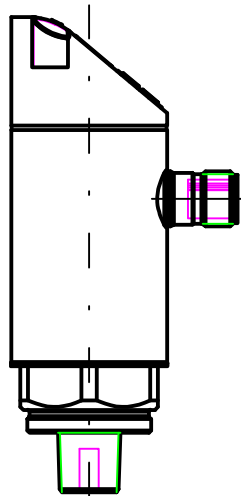
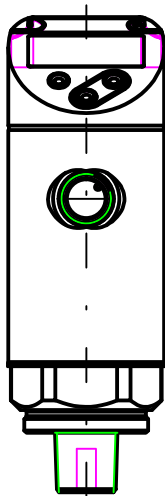

TECHNICAL DATA -

OPERATING VOLTAGE - 9.6 TO 32 VDC
 CURRENT RATING (mA) - 500
 CURRENT CONSUMPTION - <25
 OPERATING TEMPERATURE - -25 TO 80 C
 PROTECTION - IP 67 / III
 PRESSURE RANGE- 0...10 BAR 0...145 PSI

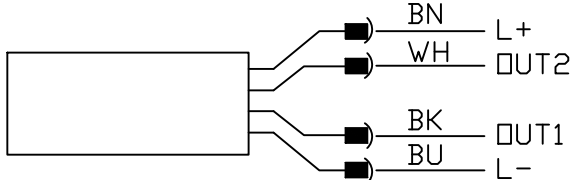

NOTE:
 USE 620-005 RIGHT ANGLE CONNECTOR
 M12 micro DC (4 pin) 5m 22 AWG, Black PUR jacket
 USE 620-006 CLEAR COVER

DWG. TITLE PRESSURE SWITCH ILLUSTRATION				HTI FILTRATION		ifm EFECTOR PN7694				
PROJECT DESCRIPTION PRESSURE SWITCH 620-018						7716 Gary Watson Pt Colorado Springs Colorado, USA, 80915		0	06-02-22	SP
JOB NO.	DRAWING NO.	REVISION	CUST. CONTR. NO.			REV.	DATE:	DRWN BY	CHKD BY	DESCRIPTION
-	620-018		-			CUSTOMER PS-ANGELUS				

7 Operating and display elements

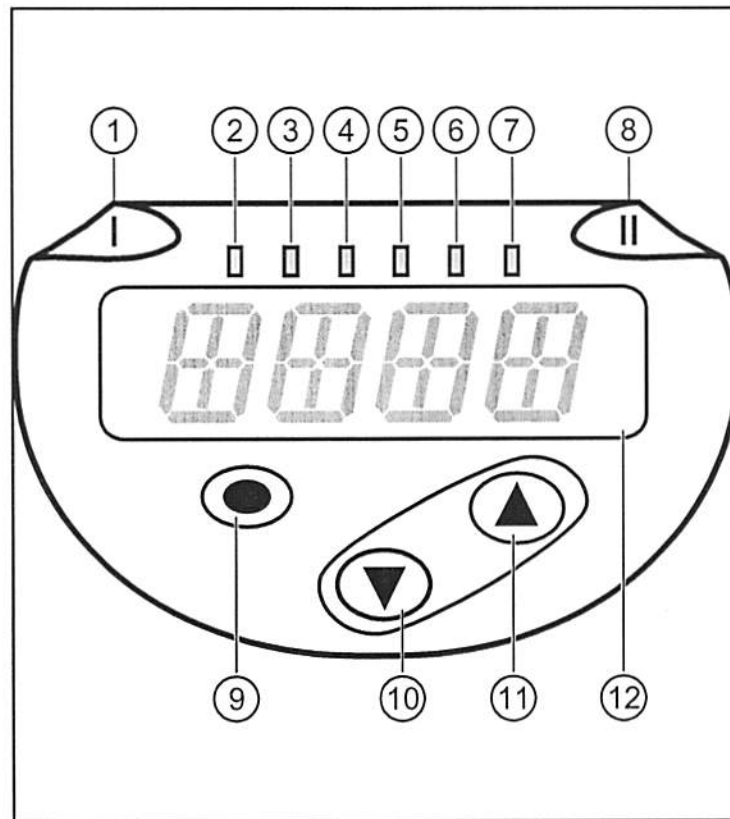

UK

1 to 8: Indicator LEDs	
LED 1	Switching status OUT1 (on if output 1 is switched).
LED 8	Switching status OUT2 (on if output 2 is switched).
LEDs 2 - 7	System pressure in the indicated unit of measurement.
9: [Enter] button [●]	
- Selection of the parameters and acknowledgement of the parameter values.	
10 to 11: Arrow keys up [▲] and down [▼]	
- Setting of the parameter values (scrolling by holding pressed, incrementally by pressing once).	
12: Alphanumeric display, 4 digits	
- Display of the current system pressure.	
- Indication of the parameters and parameter values.	

8 Menu

8.1 Menu structure: main menu

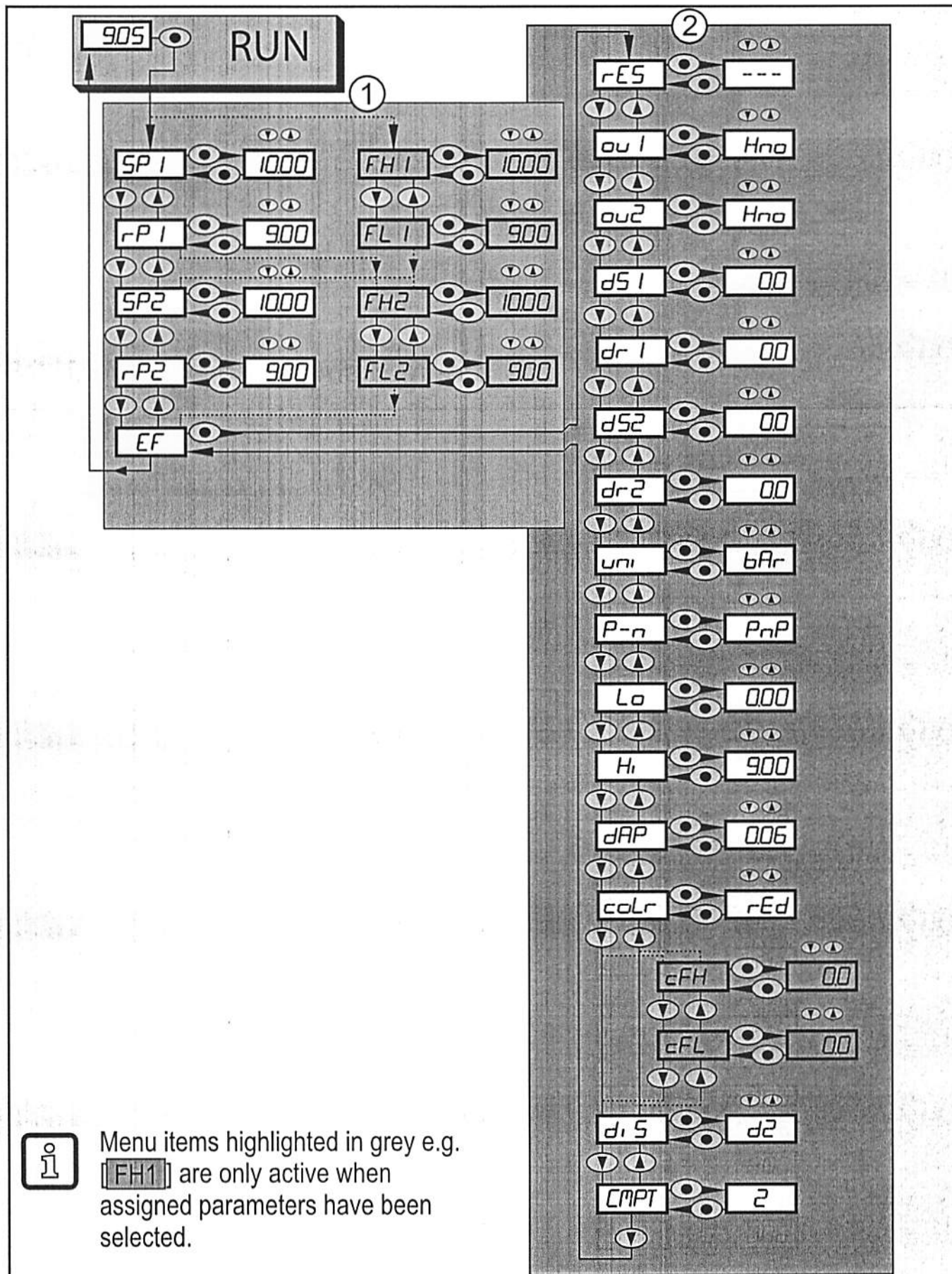

8.2 Explanation of the menu

8.2.1 Explanation of menu level 1

SPx/rPx	Upper / lower limit value for system pressure at which OUTx switches with hysteresis setting. SPx/rPx is displayed if the parameter [Hno] or [Hnc] for OUTx was set in the extended functions "EF" menu.
FHx/FLx	Upper / lower limit value for system pressure at which OUTx switches with window setting. FHx/FLx is displayed if the parameter [Fno] or [Fnc] for OUTx was set in the extended functions "EF" menu.
EF	Extended functions / opening of menu level 2.

UK

8.2.2 Explanation of menu level 2

rES	Restore factory setting.
ou1	Output function for OUT1: <ul style="list-style-type: none"> • Switching signal for the pressure limits: hysteresis function [H ..] or window function [F ..], either normally open [. no] or normally closed [. nc]. • Output off [OFF] (function only available in operating mode [3]).
ou2	Output function for OUT2: <ul style="list-style-type: none"> • Switching signal for the pressure limits: hysteresis function [H ..] or window function [F ..] as normally open (. no) or normally closed (. nc) each. • Output off [OFF] (function only available in operating mode [3]).
dS1 / dS2	Switch-on delay for OUT1 or OUT2.
dr1 / dr2	Switch-off delay for OUT1 / OUT2.
uni	Standard unit of measurement for system pressure (display): [bAr] / [mbar] / [MPa] / [kPa] / [PSI] / [inHG].  The selectable units of measurement depend on the respective unit. See table with setting ranges (→ 11.1.1).
P-n	Output logic: PNP/NPN.
Lo	Minimum value memory for system pressure.
Hi	Maximum value memory for system pressure.
dAP	Damping of the measured signal.
coLr	Assignment of the display colours "red" and "green" within the measuring range.
cFH / cFL	Upper / lower value for colour change. Parameter only active after selection of a freely definable colour window in the coLr parameter: [r-cF] or [G-cF].
diS	Update rate and orientation of the display.
CMPT	Selection of the operating mode

9 Parameter setting

During parameter setting the unit remains in the operating mode. It continues its monitoring functions with the existing parameters until the parameter setting has been completed.

9.1 Parameter setting in general

3 steps must be taken for each parameter setting:

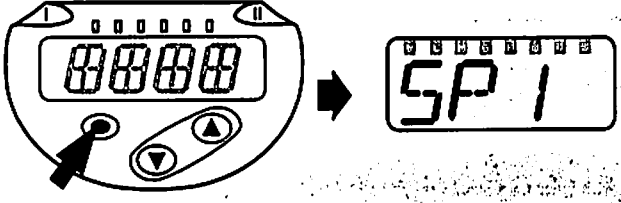
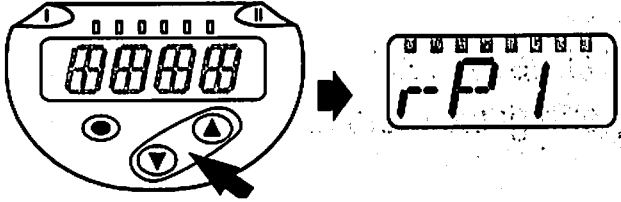
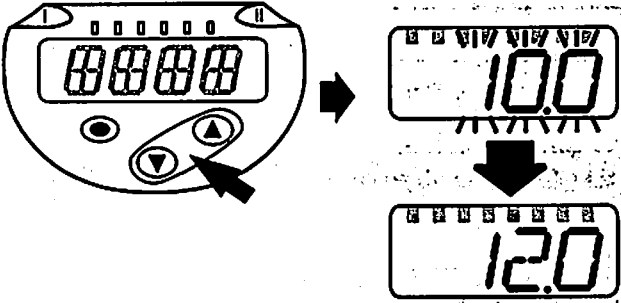
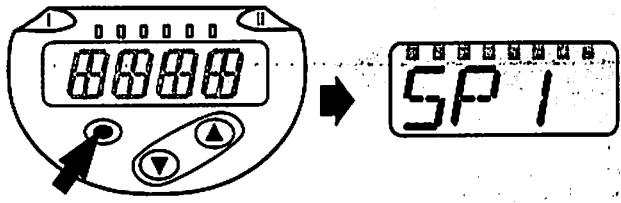
<p>1 Select parameter</p> <ul style="list-style-type: none">▶ Press [●] to get to the menu.▶ Press [▲] or [▼] until the required parameter is displayed.	 
<p>2 Set parameter value</p> <ul style="list-style-type: none">▶ Press [●] to edit the selected parameter.▶ Press [▲] or [▼] for at least 1 s.> After 1 s: setting value is changed: incrementally by pressing the button once or continuously by keeping the button pressed.	
<p>Numerical values are incremented continuously with [▲] or decremented with [▼].</p>	
<p>3 Acknowledge parameter value</p> <ul style="list-style-type: none">▶ Briefly press [●].> The parameter is displayed again. The new setting value is saved.	
<p>Set other parameters</p> <ul style="list-style-type: none">▶ Press [▲] or [▼] until the required parameter is displayed.	
<p>Finish parameter setting</p> <ul style="list-style-type: none">▶ Press [▲] or [▼] several times until the current measured value is displayed or wait for 30 s.> The unit returns to the process value display.	



If [C.Loc] is displayed when an attempt is made to modify a parameter value, an IO-Link communication is active (temporary locking).



If [S.Loc] is displayed, the sensor is permanently locked via software. This locking can only be removed with a parameter setting software.

- Change from menu level 1 to menu level 2:

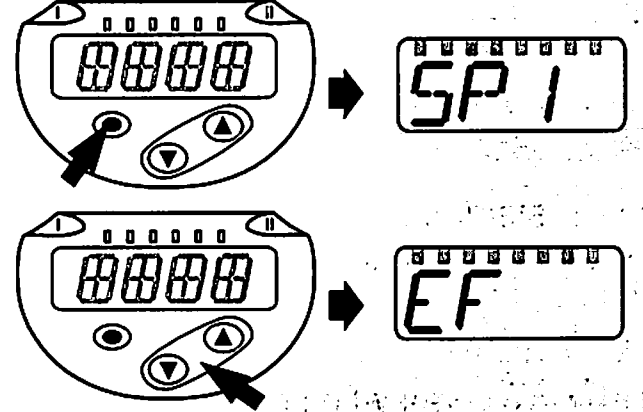
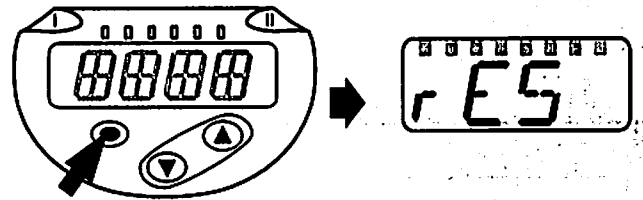
<ul style="list-style-type: none"> ▶ Press [●] to get to the menu. ▶ Press [▲] or [▼] until [EF] is displayed. 	
<ul style="list-style-type: none"> ▶ Press [●]. > The first parameter of the submenu is displayed (here: [rES]). 	

UK



Change from menu level 1 to menu level 2 when a parameter setting software is used:

Activate the [EF] button.

- Locking / unlocking

The unit can be locked electronically to prevent unintentional settings.

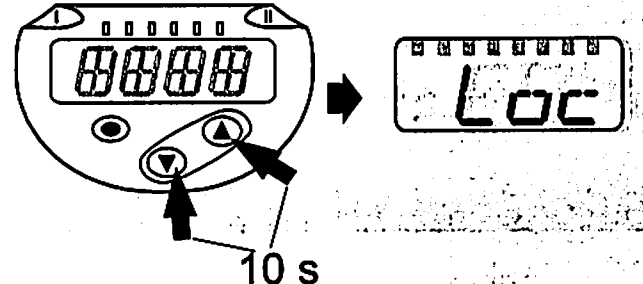
<ul style="list-style-type: none"> ▶ Make sure that the unit is in the normal operating mode. ▶ Press [▲] + [▼] simultaneously for 10 s. > [Loc] is displayed. 	
<p>During operation: [Loc] is briefly displayed if you try to change parameter values.</p>	

For unlocking:

- ▶ Press [▲] + [▼] simultaneously for 10 s.
- > [uLoc] is displayed.

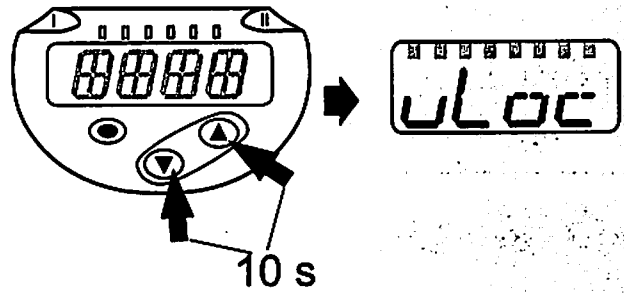

On delivery: not locked.

- **Timeout:**

If no button is pressed for 30 s during parameter setting, the unit returns to the operating mode with unchanged values.

- **Exit parameter without applying the settings**

To exit a parameter without applying the settings:

- ▶ Press [▲] + [▼] simultaneously.
- > Return to the menu level.

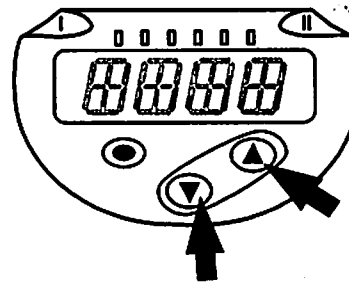

- **Exit menu level**

To exit the menu level:

- ▶ Press [▲] + [▼] simultaneously.
- > Menu level 2 changes to level 1 or level 1 changes to the display.

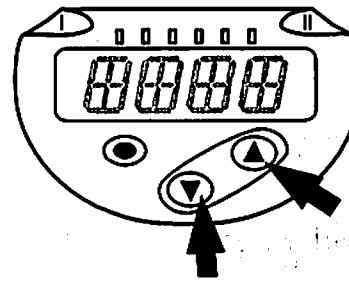

10.2 Self-diagnostics / fault indications

The unit has many self-diagnostic options.

- It monitors itself automatically during operation.
- Warnings and faults are displayed (even if the display is deactivated), in addition they are available via IO-Link.

Display	Status LED OUT1	Status LED OUT2	Type of fault *)	Fault / warning	Corrective measures
PARA			F	Parameter setting outside the permissible range.	▶ Repeat parameter setting.
none			F	Supply voltage too low.	▶ Check / correct the supply voltage.
SC Flashes	Flashes	Flashes	F	Excessive current on switching outputs OUT1 and OUT2 **).	▶ Check switching outputs for short circuit or excessive current; Remove the fault.
SC1 Flashes	Flashes		F	Excessive current at switching output OUT1 **).	▶ Check switching output OUT1 for short-circuit or excessive current; Remove the fault.
SC2 Flashes		Flashes	F	Excessive current at switching output OUT2 **).	▶ Check switching output OUT2 for short-circuit or excessive current. Remove the fault.
Loc			W	Parameter setting locked via buttons.	▶ Unlock buttons (→ 9.1 Parameter setting in general) → "Locking / unlocking".
C.Loc			W	Parameter setting locked via pushbuttons, parameter setting is enabled via IO-Link communication (→ 9.1).	▶ Wait until parameter setting via IO-Link is finished.
S.Loc			W	Setting buttons locked via parameter software. Parameter change is rejected (→ 9.1).	▶ Unlocking only possible via IO-Link interface / parameter setting software.

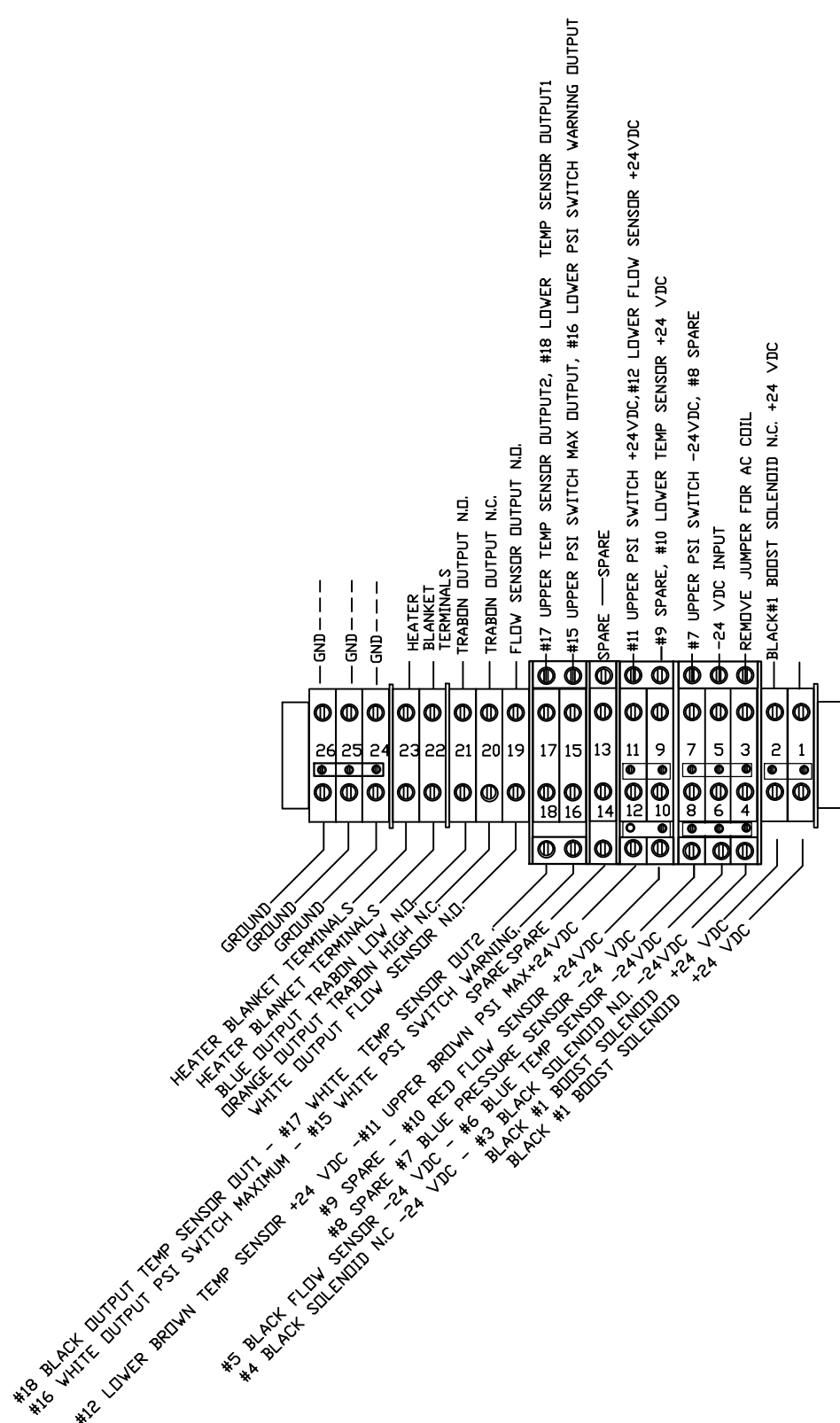

DWG. TITLE 830-001.3.1 CONNECTOR BLOCK				HTI FILTRATION INC.		830-001.3.1 CONNECTOR BLOCK				
PROJECT DESCRIPTION FO029H614 FILTRATION UNIT				7716 GARY WATSON PT COLORADO SPRINGS COLORADO USA 80906		B	05-26-21	SP	RH	CHANGE PRESSURE SENSOR
						A	08-15-20	SP	RH	ADD TEMP SENSOR
						0	07-31-13	SP	SP	ORIGINAL ISSUE
DATE 02-17-2022	DRAWING NO. 830-001.3.1	REVISION 0	CUST. CONTR. NO. -			REV.	DATE:	DRWN BY	CHKD BY	DESCRIPTION
						CUSTOMER PNEUMATIC SCALE -ANGELUS				

DIGITAL PRESSURE SENSOR
WARNING & SHUT-OFF
PROVIDE CHANGE FILTER ALERT-
SHUTS DOWN SEAMER OPERATION
SHOULD BE FIELD ADJUSTED TO SYSTEM
OPERATING CONDITIONS

FLOW SWITCH
PROVIDES LOW FLOW ALARM
NO MAINTENANCE OR ADJUSTMENT REQUIRED

TEMPERATURE SENSOR
0-150 C/0-350 F
TEMPERATURE SHOULD
BE BETWEEN 90-110F
NO MAINTENANCE REQUIRED

GEAR PUMP WITH
INTERNAL RELIEF
PROVIDES .5 GPM FLOW WITH
LOW PULSATION AND ABILITY
TO WITHSTAND WATER & DEBRIS
AIR OR OIL LEAKS INDICATE THAT SEAL
REPLACEMENT IS REQUIRED

COMPOUND GAUGE
0-30 PSI/0-30 Hg
PROVIDES INDICATION OF FLOW
VACUUM OF 0-15" IS TYPICAL
OPEN VALVE AT START-UP
IN CASE MOTOR IS ROTATING
BACKWARDS
NO MAINTENANCE REQUIRED

DIFFERENTIAL PRESSURE SWITCH -OPTIONAL KIT
SHOWS ACTUAL PRESSURE DRDP ACROSS
EACH FILTER TO MAXIMIZE FILTER
LIFE
NO MAINTENANCE REQUIRED

DIFFERENTIAL PRESSURE SWITCH -OPTIONAL KIT
SHOWS ACTUAL PRESSURE DRDP ACROSS
EACH FILTER TO MAXIMIZE FILTER
LIFE
NO MAINTENANCE REQUIRED

CHECK VALVE
PREVENTS BACKFLOW TO RESERVOIR
NO MAINTENANCE REQUIRED

THREE WAY SOLENOID VALVE
DISTRIBUTES CLEANED OIL TO RESERVOIR, UPPER TURRET ETC.
NO MAINTENANCE REQUIRED, N/O SOLENOIDS SHOW CHROME COLLAR AT REST

THREE WAY SOLENOID VALVE
DISTRIBUTES CLEANED OIL TO TRABON RESERVOIR, UPPER TURRET FLUSH
NO MAINTENANCE REQUIRED, N/O SOLENOIDS SHOW CHROME COLLAR AT REST

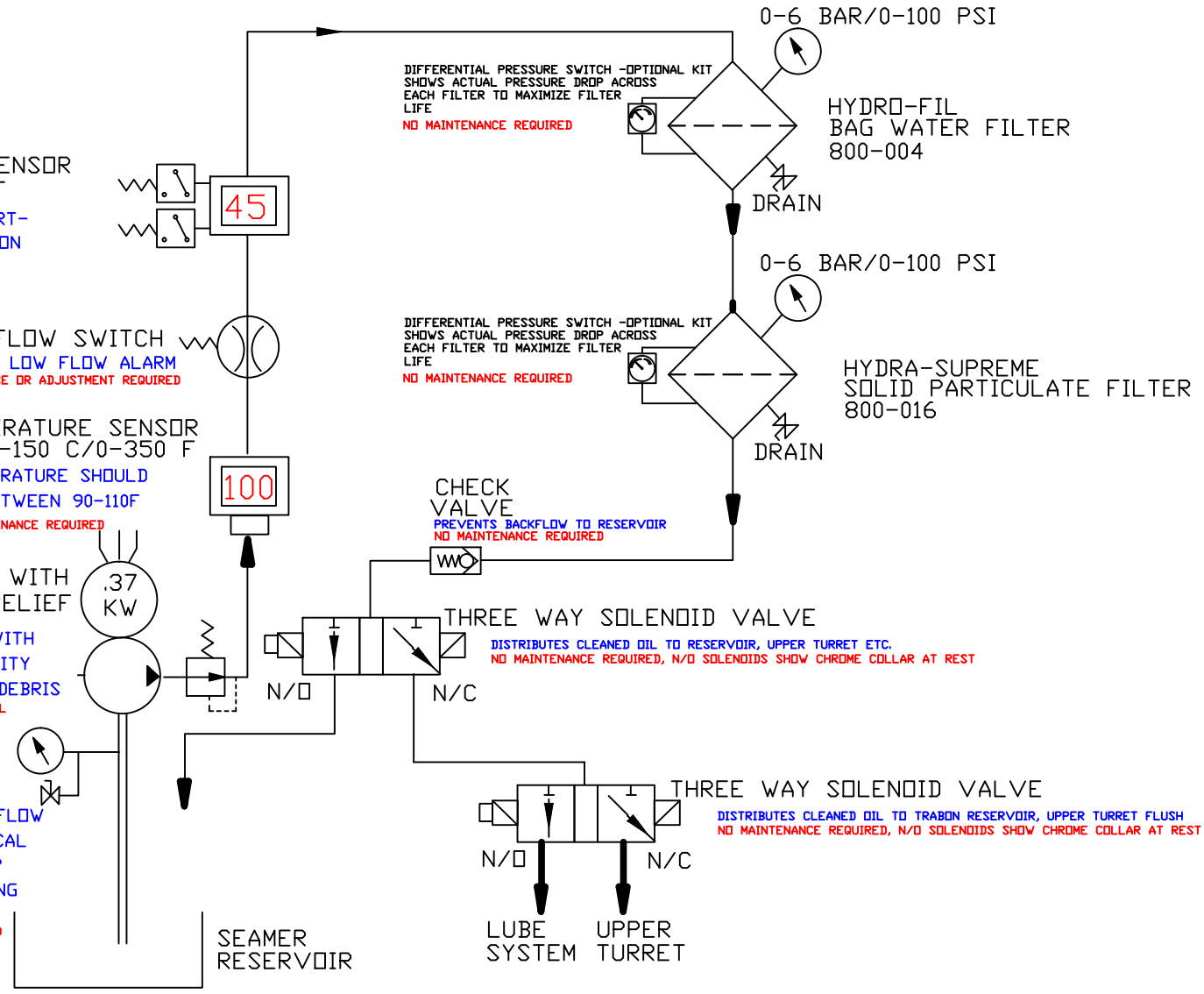

DWG. TITLE PSA MAINTENANCE SCHEMATIC				HTI FILTRATION INC.				830-001 R-9- F029H614			
PROJECT DESCRIPTION SEAMER PARTICULATE AND WATER REMOVAL SYSTEM								7716 GARY WATSON PT COLORADO SPRINGS COLORADO, USA 80915			
JOB NO.	DRAWING NO.	REVISION	CUST. CONTR. NO.	C	SP	RH	SP	RH	SP	RH	ADD CHECK VALVE
-	830-ASC MS	C	-		REV.	DATE:	DRWN BY	CHKD BY			DESCRIPTION
								CUSTOMER PNEUMATIC SCALE - ANGELUS			

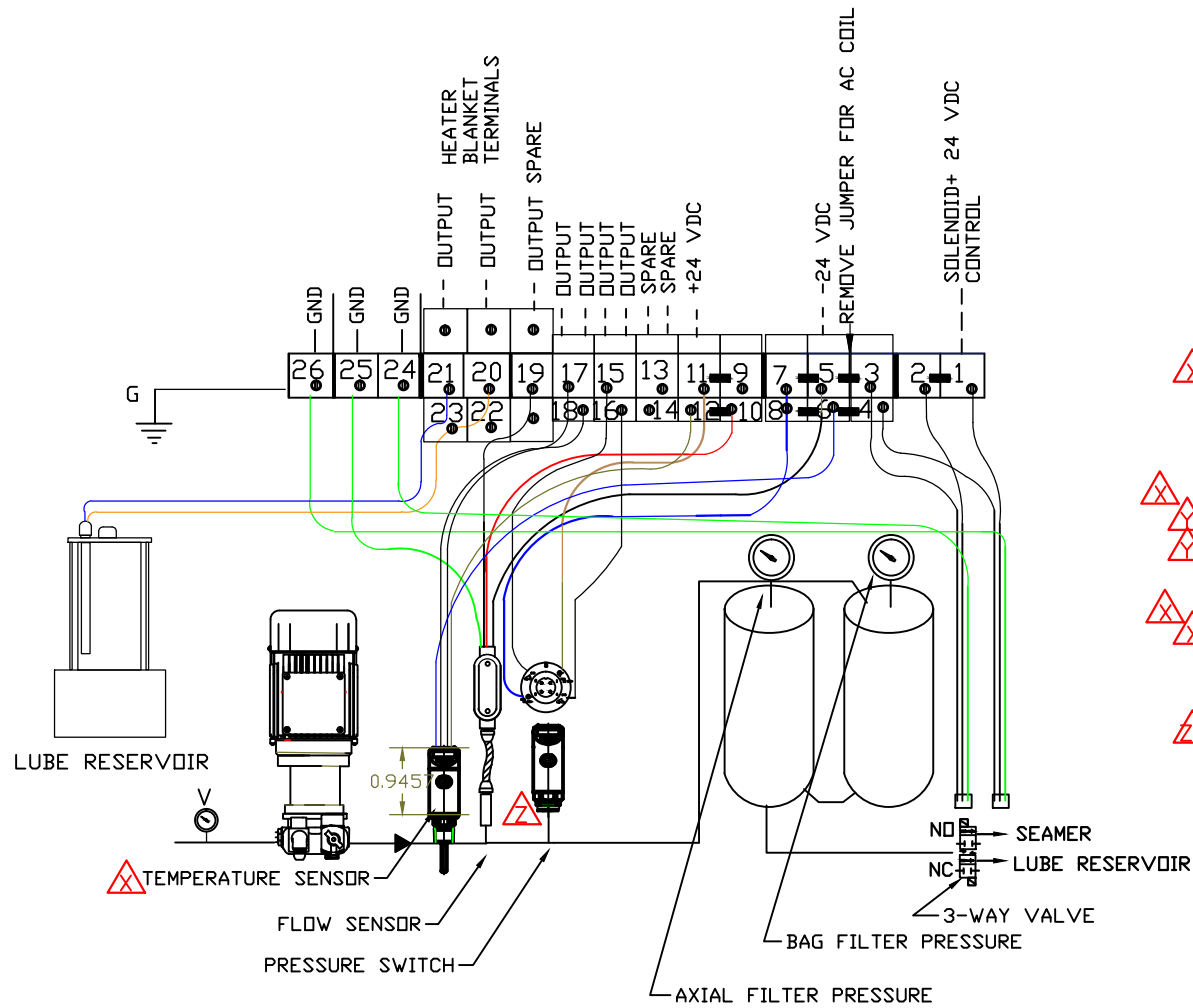

WIRE COLOR CODE

- 1. BLACK #1 Boost Solenoid N/D +24VDC
- 2. BLACK #1 Boost Solenoid N/C +24VDC
- 3. BLACK #2 Boost Solenoid N/C -24VDC
- 4. BLACK #2 Boost Solenoid N/D -24VDC
- 5. BLACK Flow Sensor -24VDC
- △ 6. BLUE Temperature Sensor -24VDC
- 7. BLUE PSI Switch Max -24VDC
- 8. SPARE
- 9. SPARE
- 10. RED Flow Sensor +24VDC
- 11. BROWN PSI Switch +24VDC
- 12. BROWN Temperature Sensor +24VDC
- 13. SPARE
- 14. SPARE
- 15. WHITE PSI Switch Warning Output #2
- 16. BLACK PSI Switch MAXIMUM Output #1
- 17. WHITE Temperature Sensor Output , Out2
- △ 18. BLACK Temperature Sensor Output. OUT1
- 19. WHITE Flow sensor Output , N/D
- 20. ORANGE Trabon High Output N.C.
- 21. BLUE Trabon Low Output N.D.
- △ 22. Heater Band
- 23. Heater Band
- 24. GREEN/YELLOW ST Flow Sensor GND .
- 25. GREEN/YELLOW ST Boost Solenoid N/C .
- 26. GREEN/YELLOW ST Boost Solenoid N/D .

- △ 640-004 TEMPERATURE SENSOR-DIGITAL
- △ 620-018 PRESSURE SWITCH-DIGITAL DISPLAY

DWG. TITLE 830-001.3.1 WIRING LAYOUT				HTI FILTRATION INC.		830-001.3.1 R-9,R-10 830-002				
PROJECT DESCRIPTION FO029H614				7716 GARY WATSON PT COLORADO SPRINGS COLORADO USA 80906		Z-1	06-01-23	SP	SP	DOUBLE UP 20-23
DATE 06-06-23				DRAWING NO. 830-001.3.1 WS		Z	05-26-21	SP	SP	PRESS.SENSOR CHANGE
REVISION Z-1				CUST. CONTR. NO. -		Y	06-25-20	SP	SP	WIRING CHANGE
						REV.	DATE:	DRWN BY	CHKD BY	DESCRIPTION
						CUSTOMER PNEUMATIC SCALE-ANGELUS				

TROUBLESHOOTING GUIDE
ANGELUS SANITARY CAN SEAMER FILTRATION SYSTEM
HYDRA-SUPREME MODEL 830-001.3.1 R3-R-10

When using this guide please remember that all pressure and flow readings are to be taken with the system at normal operating temperatures.

SYMPTOM	CAUSE	CORRECTIVE ACTION
ERRATIC FLOW RATE, BUBBLES IN OIL STREAM	AIR LEAK IN FITTINGS, BLEED COCK OR VACUUM GAUGE	CONFIRM THAT VACUUM BLEED AND GAUGE ARE AIR TIGHT, CHECK FITTINGS
	AIR LEAK UNDER RELIEF PUMP ADJUSTMENT NUT	MAKE SURE TORQUE STRIPE ON ACORN NUT IS INTACT, REPLACE SEAL IF BROKEN
	LOOSE OR PINCHED FEED TUBE CONNECTION	MAKE SURE ALL PLUMBING CONNECTIONS ARE TIGHT
	LOW FLUID LEVEL	CHECK FLUID LEVEL IN RESERVOIR
EXCESSIVE VACUUM (ABOVE 15")	FLOW RESTRICTION	CHECK INLET PIPING FOR RESTRICTION, BLOCKAGE
	INLET PIPING RESTRICTION	CONFIRM ¾"-1" INLET PIPING SIZE
	OIL TOO THICK (OVER 900 SUS @100°F)	CHANGE TO LIGHTER GRADE OF OIL
	ENVIRONMENT TOO COLD - LESS THAN 60° FARENHEIT	INSULATE FEED LINE TO FILTER, HEAT CANISTERS
	SEAMER RUNS TOO COLD-OIL DOESNT' GET OVER 80° F.	CHANGE TO LIGHTER GRADE OIL
	AMBIENT AIR AND SEAMER TEMPERATURE UNDER 80° F.	INSTALL HEAT BLANKET ON FILTER CANISTER
LOW FLOW RATE WITH LOW PRESSURE	AIR BUBBLE IN PUMP	OPEN AIR VENTS TO BLEED OF AIR
	INSUFFICIENT MOTOR POWER GENERATED	CHECK FOR PROPER PUMP VOLTAGE AND ROTATION
	OIL BYPASSING THROUGH RELIEF VALVE	CHECK RELIEF VALVE FOR PROPER SETTING

SYMPTOM	CAUSE	CORRECTIVE ACTION
LOW FLOW RATE WITH HIGH PRESSURE	LOADED FILTER	REPLACE FILTER ELEMENT
	RESTRICTED OUTLET LINES	CHECK AND CLEAR RETURN LINES
EXCESSIVE PRESSURE	RELIEF VALVE SET TOO HIGH	CHANGE FILTER AND RE-SET RELIEF VALVE TO 65 PSI
PUMP WON'T WORK AFTER ELEMENT CHANGE OR STRAINER CLEANING	VACUUM LOCK IN PUMP	BLEED AIR OFF AT BLEED VALVE ON PUMP OUTLET
UPPER TURRET OR LUBRICATOR WON'T FILL	FAULTY SOLENOID COIL	CHECK COIL ON SOLENOID, REPLACE IF DEFECTIVE
CANISTERS LEAK AT LID CLAMP	CUT OR ERODED SEAL	CHECK SEALS FOR DAMAGE
	LID NOT TIGHT	TIGHTEN CLAMP BOLT

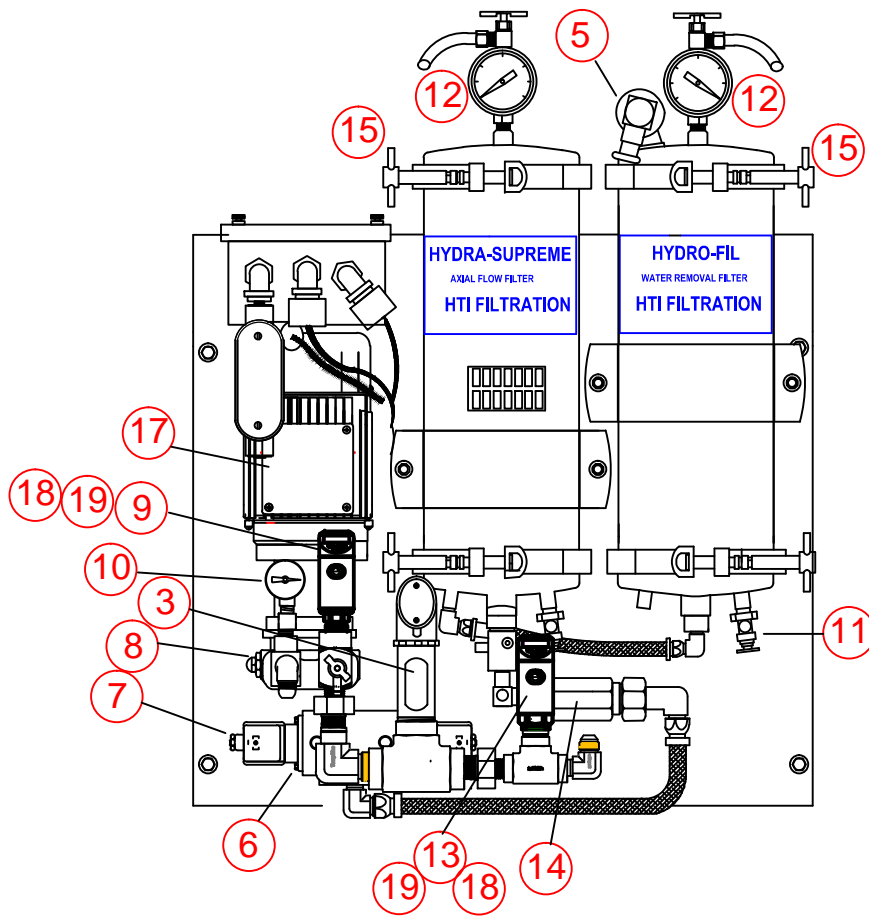

REPLACEMENT PARTS

ITEM NO.	DESCRIPTION	DWG. NO
1	SOLIDS FILTER	800-016
2	WATER BAG	800-004
3	FLOW SENSOR 12-24DCV	620-010
4	O-RING	450-001
5	QDC - M,F	430-001,002
6	SOLENOID VALVE- VDC	430-074
7	DIN CONNECTORS	250-019
8	PUMP	770-013.1
9	TEMPERATURE SENSOR	640-004
10	COMPOUND GAUGE	610-013
11	DRAIN COCK	430-004
12	PRESSURE GAUGE	610-010
13	PRESSURE SWITCH	620-018.1
14	CHECK VALVE	430-079
15	LID CLAMP	540-005
16	PUMP SEAL KIT-VITON	710-014
17	MOTOR 3 PHASE 50/60 HZ .33 HP / .25 Kw 1700 RPM	780-029
18	SENSOR- SWITCH CABLE	620-005
19	SENSOR-SWITCH COVER	620-019
20		

DWG. TITLE			
ANGELUS 830-001.3.1 SPARE PARTS			
PROJECT DESCRIPTION			
ANGELUS F029H614 - - - -			
JOB NO.	DRAWING NO.	REVISION	CUST. CONTR. NO.
-	830-001.3.1	0	-

**HTI
FILTRATION**

7716 GARY WATSON PT
COLORADO SPRINGS
CO USA 80915

830-001.3.1 R-9				
0	06-02-21	SP	SP	R-9 FIRST ISSUE
REV.	DATE:	DRWN BY	CHKD BY	DESCRIPTION
CUSTOMER PNEUMATIC SCALE -ANGELUS				



HTI FILTRATION INC.

7716 Gary Watson Pt. • Colorado Springs, CO 80915 • 719.490.8800 • sales@htifiltration.com

STANDARD WARRANTY

This filter system was inspected before shipment from our plant. To the original purchaser of this system, HTI Filtration warrants its products free from defects in material and workmanship for a period of one (1) year from date of purchase.

HTI Filtration makes no other express warranty and excludes (and buyer waives) any and all implied warranties including, without limitation to, implied warranties in connection with the design, sale, merchantability or fitness of the goods for any particular use or purpose.

In order for any claim under this warranty to be valid, HTI Filtration must receive notice in writing from the buyer within a reasonable time period, not to exceed thirty (30) calendar days after any defect is discovered. The claim must include a detailed report of the conditions of use at the time of discovery of defect. Parts which fail or become defective during the warranty period (except as a result of freezing, melting, improper installation, use or care), shall be replaced or repaired at HTI Filtration's option at no charge within 90 days of the receipt of the defective part, barring unforeseen delays. HTI Filtration shall in no event be responsible for the repairs made by others without the express written permission and consent of HTI Filtration.

To obtain warranty replacement or repairs, defective components or parts should be returned, freight prepaid, to place of purchase or nearest authorized service center. HTI Filtration shall not be responsible for cartage, removal and/or reinstallation labor or any other such costs incurred in obtaining warranty replacements. In no event shall HTI Filtration be responsible for any incidental or consequential damage, whether foreseeable or not and whether or not such damage occurs, or is discovered before or after repair or replacement.

The forgoing warranty does not apply to wear components, seals or filtration elements.

This warranty extends only to the original buyer and HTI Filtration makes no other warranty, expressed or implied, to other persons or entities. If buyer makes any warranty or representation inconsistent with or in addition to the warranty stated hereinabove, the buyer shall, at their own expense, defend and hold HTI Filtration harmless from any claim thereon of any nature whatsoever.