

### BILL OF MATERIAL

ITEM NO.	DESCRIPTION	DWG. NO
1	HEATER BLANKET	270-001
2	H203-B4L	800-051
3	O-RING	450-002
4	STROBE LIGHT BULB	270-008
5	T-HANDLE SEAL	450-003
6	DELAY TIMER	230-014
7	MOTOR	780-005
8	PUMP	770-001
9	T-HANDLE ASSEMBLY	860-001
10	VACUUM GAUGE	510-012
11	CHECK VALVE	430-048
12	PRESSURE GAUGE	610-010
13	DRAIN COCK	430-004
14	H203-B4LM	800-043
15	H203-B6LM	800-046
16	LID CLAMP	540-005

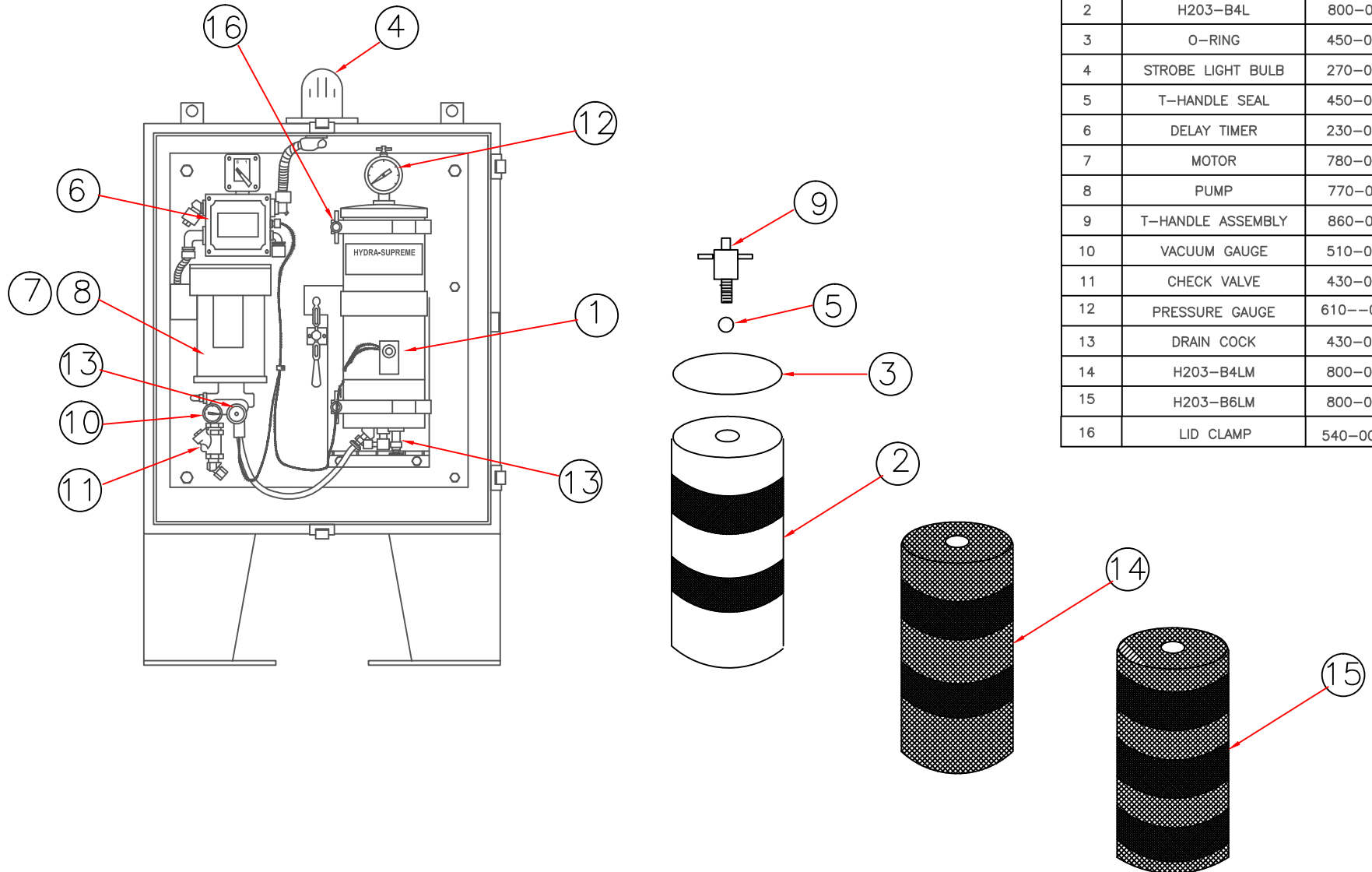

DWG. TITLE CABINET ENCLOSED FILTRATION SYSTEM				HTI FILTRATION		810-020					
PROJECT DESCRIPTION SS CABINET MOUNTED FILTRATION SYSTEM				11820 WESTERN AVE. STANTON CA 90680		0	09/10/99	SP	SP	-	
JOB NO.	DRAWING NO.	REVISION	CUST. CONTR. NO.	CUSTOMER		REV.	DATE:	DRWN BY	CHKD BY	DESCRIPTION	
-	810-020A	A	-	-							