

BILL OF MATERIAL				
NO. REQD.	ITEM NO.	DESCRIPTION	PART NO	STOLLE PART NO
	1	PRESSURE GAUGE	610-010	089699
	2	LID SEAL	450-002	089879
	3	B6L ELEMENT	800-026	088279
	4	STRUBE LIGHT BULB-120V	270-008	NONE
	5	MOTOR 810-027 60 HZ	780-013	551597
	6	1.5 GPM PUMP	770-015	090126
	7	PRESSURE SWITCH	620-001	089916
	8	START/STOP SWITCH	230-008	089917
	9	FILTER ELEMENT LIFTER	530-008	089883
	10	PRESSURE RELIEF VALVE	430-073	NONE
	11	FLOW METER	630-019	089877
	12	C-FACE PUMP ADAPTER	790-004	089915

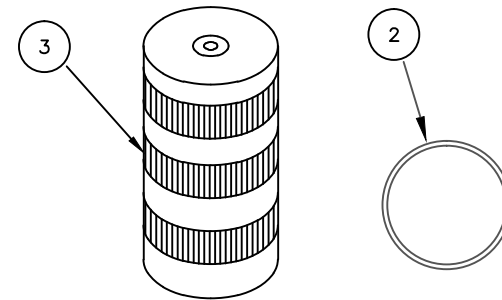

DWG. TITLE HS410-C2-B6L-C 60		HTI INC		810-027 BODYMAKER OIL FILTER				
PROJECT DESCRIPTION STOLLE -724114		11820 WESTERN AVE. STANTON CA 90680		C	09/29/00	SP	SP	CHANGE RELIEF VALVE
JOB NO. -	DRAWING NO. 810-027			REVISION C	REV.	DATE:	DRWN BY	CHKD BY
				CUSTOMER STOLLE MACHINERY				