

BILL OF MATERIAL			
NO. REQD.	ITEM NO.	DESCRIPTION	PART NO
-	1	PRESSURE GAUGE	610-010
-	2	LID SEAL	450-002
-	3	B6L ELEMENT	800-026
-	4	B6LD ELEMENT	800-045
-	5	MOTOR 3 PHASE 50/60 HZ METRIC	780-024
-	6	PUMP-NON-RELIEVED	770-024
-	7	PRESSURE SWITCH	620-001
-	8	HIGH VOLTAGE CABLE 16-4 SOOW	-
-	9	LOW VOLTAGE CABLE 18-4 SOOW	-
-	10	PRESSURE RELIEF VALVE	430-084
-	11	MOTOR 50/60 HZ WASH DOWN	780-015
-	12	FLOW METER 0-5 GPM/0-19 LPM	630-006

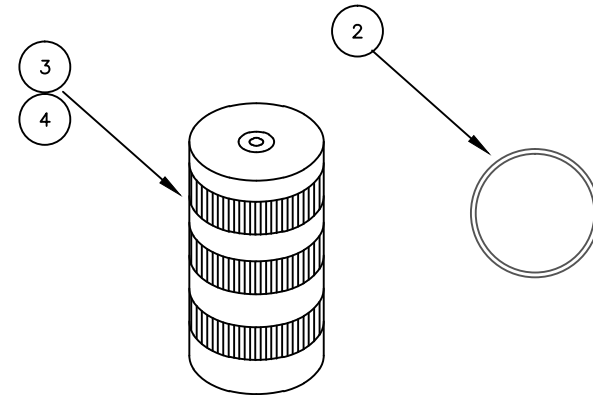

DWG. TITLE <b>810-051.0 PARTS LIST</b>		<b>HTI FILTRATION</b>		<b>BODYMAKER-CUPPING PRESS EXTERNAL PRESSURE RELIEF</b>				
PROJECT DESCRIPTION <b>HYDRA-SUPREME LUBRICATING OIL FLUID FILTER</b>		11820 WESTERN AVE. GARDEN GROVE, CA 90680		0	07-15-08	SCP	SP	ORIGINAL ISSUE
DRAWING NO. <b>810-051.0 M-3 PL</b>		REVISION	CUST. CONTR. NO.	REV.	DATE:	DRWN BY	CHKD BY	DESCRIPTION
			-	CUSTOMER				-